

HIGHLEAD

GC20688-1/-2BDL

**Single-needle/Twin-needle Long arm heavy duty
compound feed lockstitcher with trimmer**

**Instruction Manual
Parts Catalog**

SHANGHAI HUIGONG NO.3 SEWING MACHINE FACTORY

From the library of: Superior Sewing Machine & Supply LLC

1. PRECAUTIONS BEFORE STARTING OPERATION

1) Safety precautions

- (1) When turning the power on, keep your hands and fingers away from the area around/under the needle and the area around the pulley.
- (2) Power must be turned off when the machine is not used, or when the operator leaves his/her seat.
- (3) The power must be turned off before tilting the machine head, installing or adjusting the machine, or when replacing.
- (4) Avoid placing fingers, hairs, bars etc. nears the pulley, bobbin winder pulley, when the machine is operation. Injury could result.
- (5) Do not insert fingers into the thread take-up cover, under/round the needle, or pulley when the machine is in operation.
- (6) If a mini motor cover, finger guard, and/or eye guard are installed, do not operate the machine without these safety devices.

2) Precaution before starting operation

- (1) If the machine's oil pan has an oil sump, never operate the machine before filling it.
- (2) If the machine is lubricated by a drop oiler, never operate the machine before lubricating.
- (3) When a new sewing machine is first turned on, verify the rotational direction of the pulley with the power on. (The pulley should rotate counterclockwise when viewed from the pulley.)
- (4) Verify the voltage and (single or three) phase with those given on the machine nameplate.

3) Precaution for Operating Conditions

- (1) Avoid using the machine at abnormally high temperature (35°C or higher) or low temperatures (5°C or lower). Otherwise, machine failure may result.
- (2) Avoid using the machine in dusty conditions. Avoid using the machine in areas where too much electrical noise, resulted from the high-frequency welder and others, is generated

2. SPECIFICATIONS

Item		GC20688-1BDL	GC20688-2BDL
Max. Speed		2400rpm	2400rpm
Stitch length		0 to 9mm	0 to 9mm
Needle bar stroke		34mm	34mm
Presser foot clearance	By hand	9 mm	9 mm
	By knee	16 mm	16 mm
Rotating hook		Large vertical hook (2.5times)	Large vertical hook (2.5 times)
Needle		DP×17 #18-#25	DP×17 #18-#25
Presser foot alternation		1-7mm	1-7mm
Auto presser foot lifter		Pneumatic	Pneumatic
Oil lubrication method		Automatic lubrication	Automatic lubrication
Bed dimensions		710×140 mm	710×140 mm
Needle gauge (mm)			3.2 6 8 10 12 16

If sewing with stitch length of 6 mm or more, set the sewing speed to 1600 rpm or less.

3. PREPARATION BEFORE STARTING TO OPERATE

1) Connection of control box

It shows the connection of the electrical wires of the whole machine on the right picture.

When the machine needs to be assembled, each line should be linked to the right joint according to the instruction of the picture.

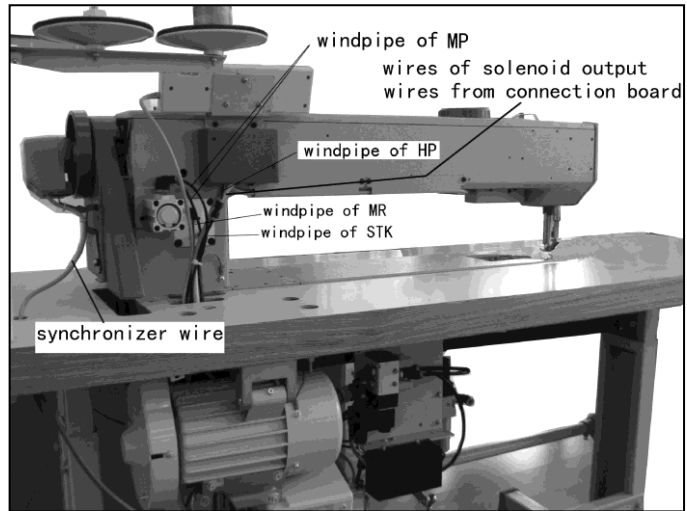

All the pins on the control box have signals of function showing, and usually, different wires have different kinds of joint.

Caution: the pin of synchronizer wire is the same with another two external pins and if there is a misconnection, the synchronizer might be burn.

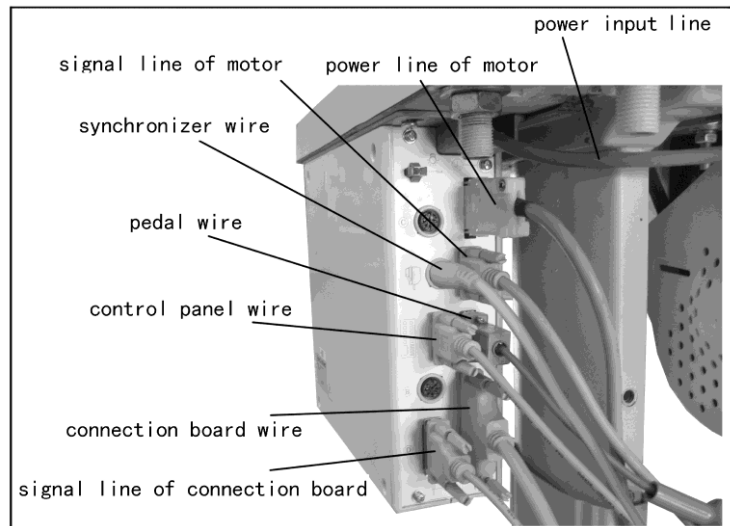

When connecting the pipes, please check the joint at the picture of the whole machine above as reference.

And also there have an instruction mark of each joint of the solenoid at the setting board.

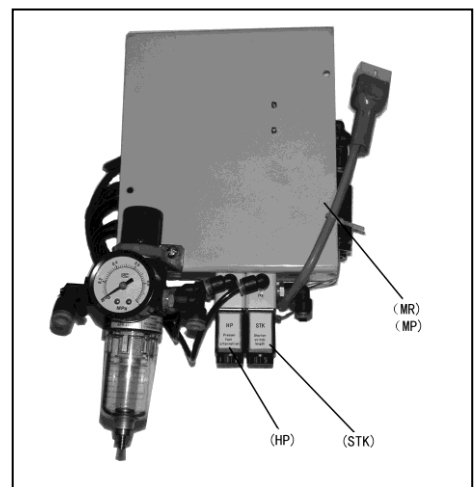

2) Oil pan

(1) Install the oil pan 3 to the underside of the worktable 1 in the place shown in the illustration using the nails 2.

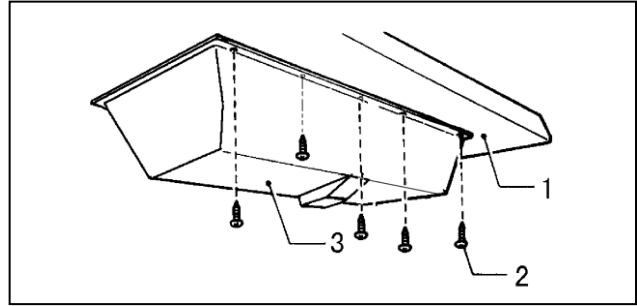

(2) From front view, the oil pan 3 to the side is 60mm; from right view, the oil pan 3 to the side is 80mm.

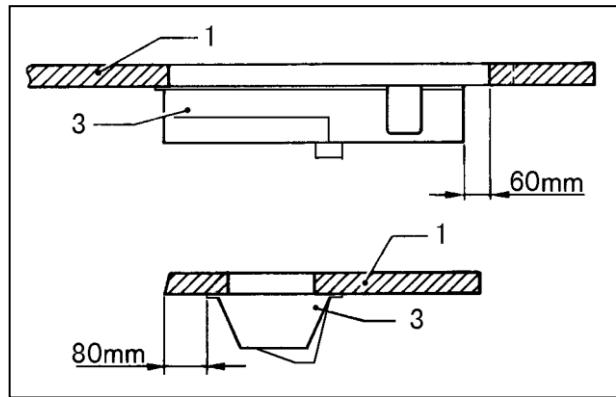

3) Operation panel

(1) Install the operation panel 1 to the set plate 2 with the three screws 3.

(2) Install the set plate 2 to the back of the machine arm with the two screws 4.

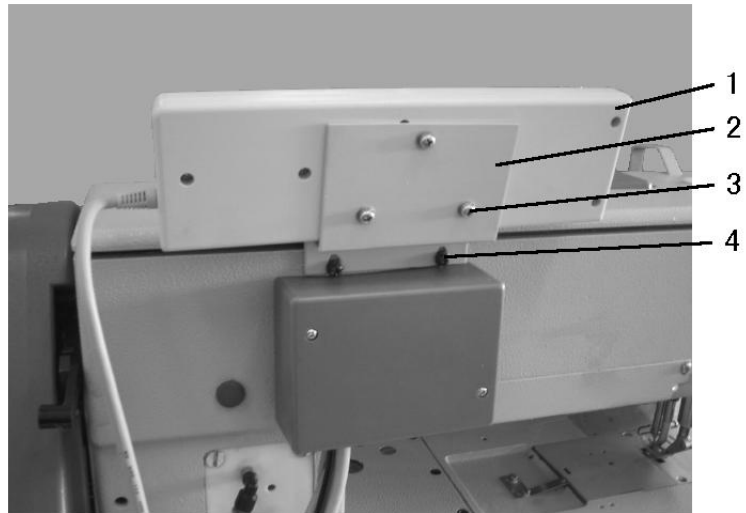

4) Adjusting the needle stop position

(1) Adjusting the needle up stop position

When the sewing machine stops in the needle up stop position (the stop position of trimming) and the treadle is pressed back, the red mark on the pulley should be consistent with the mark on the belt cover A. Adjust as follows:

- a. Turn off the power switch.
- b. Loosen the screw 4, and then remove the cover 3.

c. When the red mark stops in a position over the mark on the belt cover, the needle up stop position disc 1 should be turned in the opposite direction as the direction of machine pulley rotation. When the red mark stops in a position under the mark on the belt cover, Turn the disc 1 in the same direction as the pulley rotation direction.

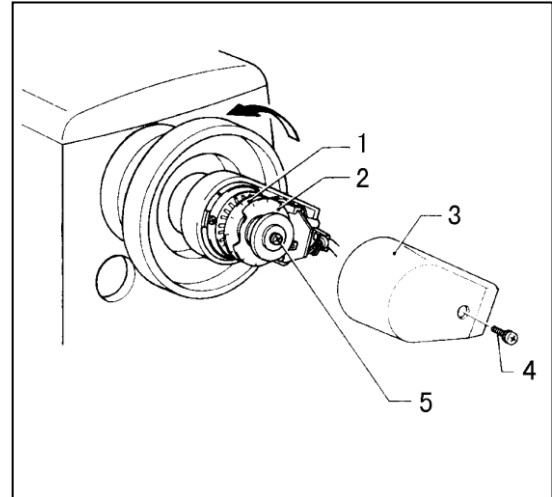
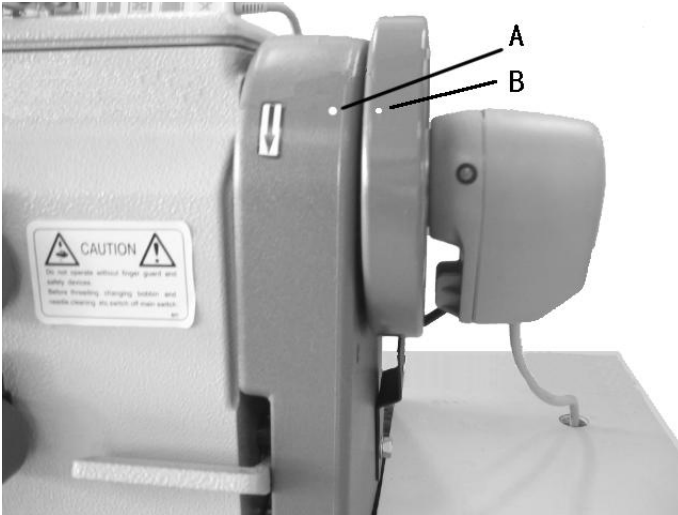

(2) Adjusting the needle down stop position

When the sewing machine stops in the needle down stop position, the black mark on the pulley should be consistent with the mark on the belt cover A. Adjust as follows:

a. Turn off the power switch.

b. When the black mark stops in a position over the mark on the belt cover, the needle down stop position disc 2 should be turned in the opposite direction as the direction of machine pulley rotation. When the black mark stops in a position under the mark on the belt cover, Turn the disc 2 in the same direction as the pulley rotation direction.

c. After adjusting, install the cover 3, with screw 4.

Note: There is no need to loosen the screw 5, when turning the discs.

5) Lubrication

Before the new machine is used, please loosen the screw 2 and full the oil into the oil case. Set the oil level between “EMPTY” and “FULL”. Then replace oil-filling screw 2.

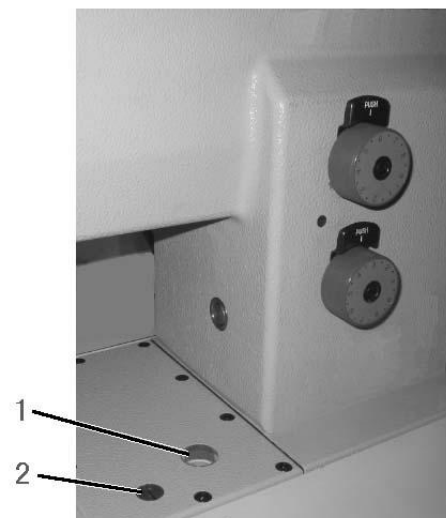

4. HOW TO USE THE MACHINE

1) Threading

Raise the thread take-up lever to its highest position and thread the upper thread in the following order.

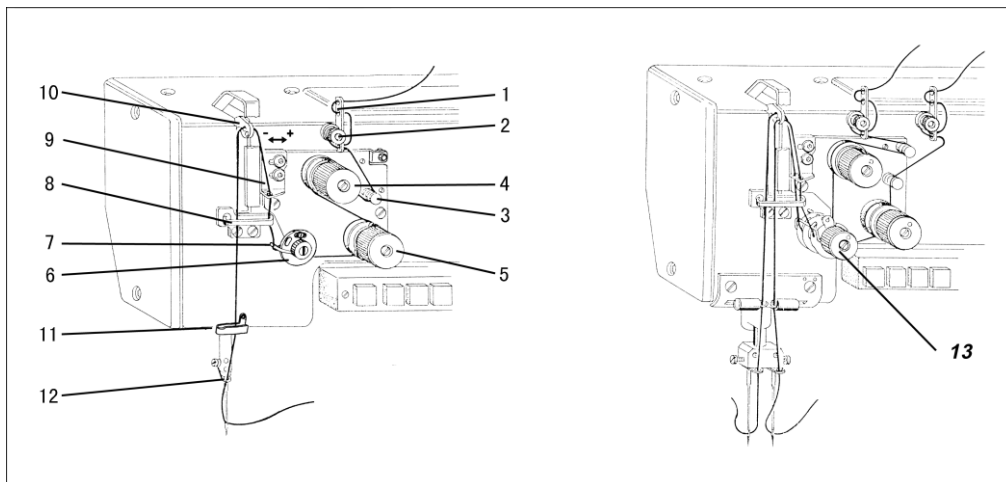

2) Adjusting of the thread regulator

The thread regulator 9 (see the right picture) regulates the amount of needle thread necessary for stitch formation. The setting depends on the following factors: material thickness, yarn characteristics and stitch length.

The thread regulator is fitted with slots for this purpose. Moving in the “+” direction increases the quantity of needle thread; Moving in the “-” direction reduces the quantity of needle thread.

3) Adjusting of upper thread tension

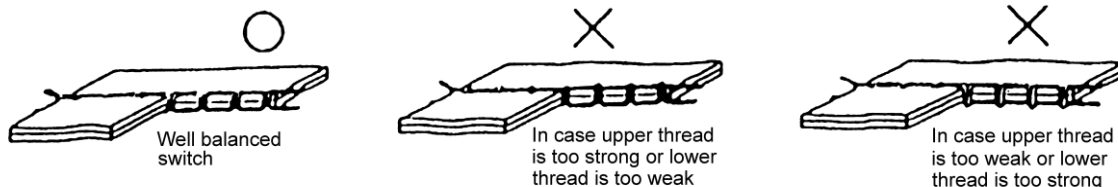

Tension should be as low as possible. The crossover point should be in the center of the material. Upper thread tension can be adjusted by thread tension nut 4 and 5 (see the picture of above). Turn the thread tension nut clockwise to increase the needle thread tension. Turn the thread tension nut counter-clockwise to decrease the needle thread tension.

4) Winding the lower thread

(1) Place the bobbin onto the bobbin winder shaft.

(2) Pass the thread for winding thread as shown in the figure, and wind the end of the thread clockwise around the bobbin several times.

(3) Push the bobbin presser 1 toward the bobbin.

(4) The operation will automatically stop when winding is completed. The amount of thread wound onto the bobbin should be a maximum of 80% if the bobbin capacity.

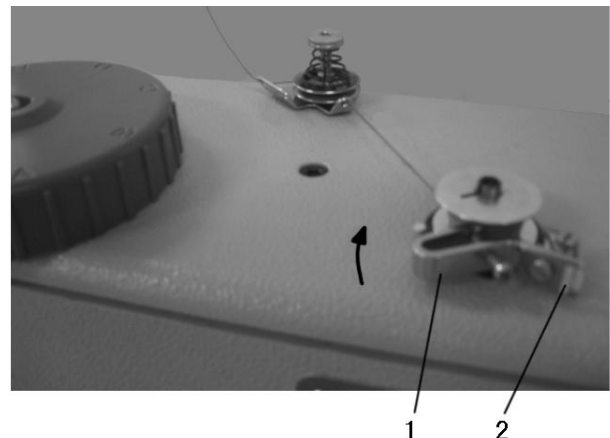

(5) After the thread has been wound on, remove the bobbin and cut the thread with the thread-trimming knife 2.

5) Threading the lower thread

(1) Raise flap 1 and remove the empty bobbin.

(2) Insert bobbin 2 in such a way that when the thread is unwound from it moves in the opposite direction to the gripper.

(3) Pass the thread through slit 3 and below spring 6, pass the thread through slit 4 and pull about 3 cm through.

(4) Close flap 1 and pass the thread through the flap's guide 5.

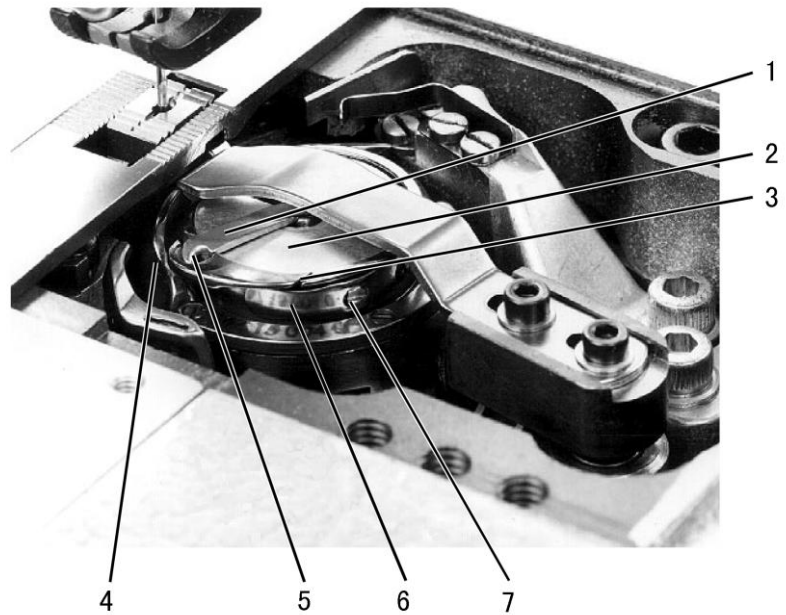

6) Adjusting the lower-thread tension

The lower-thread tension should be set in accordance with the type of seam required. Adjust the tension with screw 7. (See the picture of above)

7) Installing the needle

Note: Before attach needle, be sure to turn off the power.

1) Turn the balance wheel by hand to raise the needle bar to its highest position;

2) Loosen the needle clamping screw;

3) Hold the needles so that the two needles side with the long grooved (faces each other), and insert it as deeply as it will go into the needle clamping holes(model GC20688-2-D);Hold the needle to its side with the long groove side(left),then insert the needle as deeply as it will go into the needle clamping hole(model GC20688-1-D).

4) Tighten the needle clamping screw.

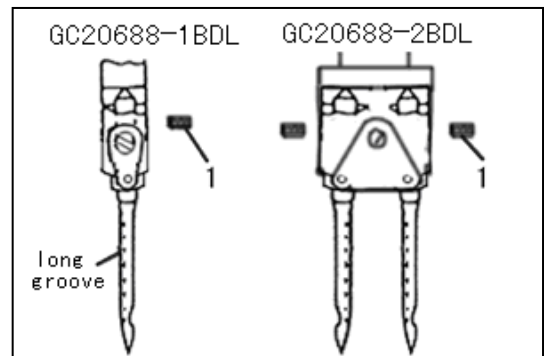

8) Alternating presser foot movement amount

The alternating movement amount for the inner presser foot and the outer presser foot can be adjusted within the range of 1-7 mm using the alternating presser foot movement dial 1. Turn the alternating presser foot movement dial 1 clockwise or counterclockwise to align the mark. (MIN. A, B, C, D, E, F MAX.)

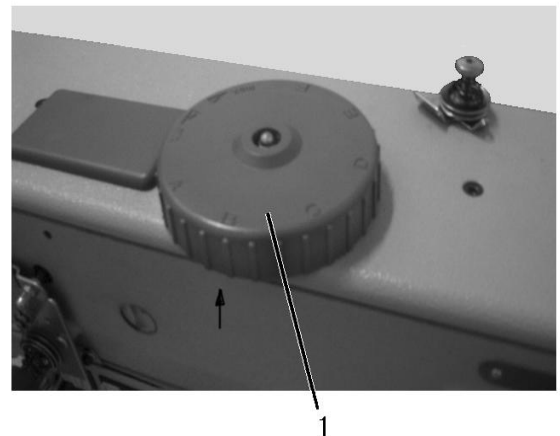

9) Adjusting the presser foot pressure

The presser foot pressure should be set as weak as possible, but strong enough so that the material does not slip. If the presser-adjusting dial 1 is turned clockwise, the presser foot pressure will become stronger, and if it is turned counterclockwise, the pressure will become weaker.

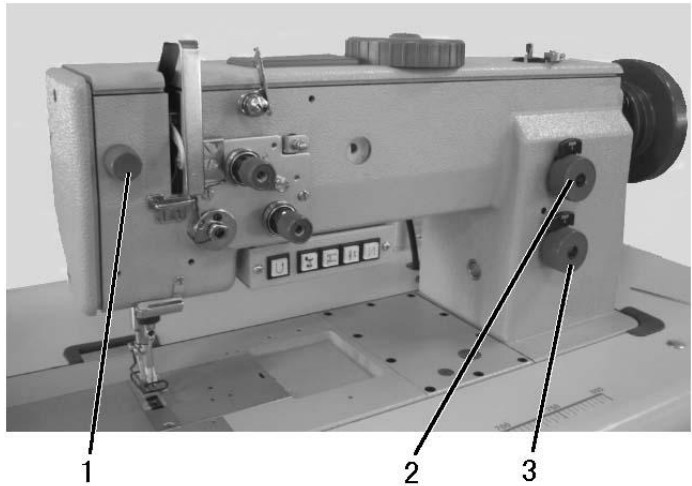

10) Adjusting the stitch length

The feed adjustment dials 2 and 3 can be used to set two different types of stitch length. (See the picture of above) Use feed adjustment dial 2 to set the big stitch length. Use feed adjustment dial 3 to set the little stitch length. The sewing machine will switch between the two stitch lengths each time the stitch length change switch is pressed.

11) Using the manual switches

(1) Quick reverse switch

Back tacking is carried out during sewing only while the switch 1 is being pressed.

(2) Alternating presser foot movement change switch

The sewing machine can be switched between two different alternating presser foot movement amounts each time when the switch 2 is pressed.

(3) Auto back tacking select switch

If the switch 3 is pressed when either start back tacking or end back tacking has been set to ON at

the operation panel, back tacking is canceled for the first time only. Furthermore, if the switch 3 is pressed when neither starting nor end back tacking has been set, back tacking is carried out for the first time only.

(4) Needle up or down switch

If the switch 4 is pressed, The needle will move up to the needle up stop position from down stop position or move down to the needle down stop position from up stop position.

(5) Stitch length change switch

The stitch length changes alternately between two different stitch length settings each time the switch 5 is pressed. OFF: Sewing is carried out using the big stitch length; ON: Sewing is carried out using the little stitch length.

(6) Feed wheel switch 6:

If the switch is pressed, the feed wheel will move up to the feed wheel up stop position from down position or move down to the feed wheel down stop position from up position.

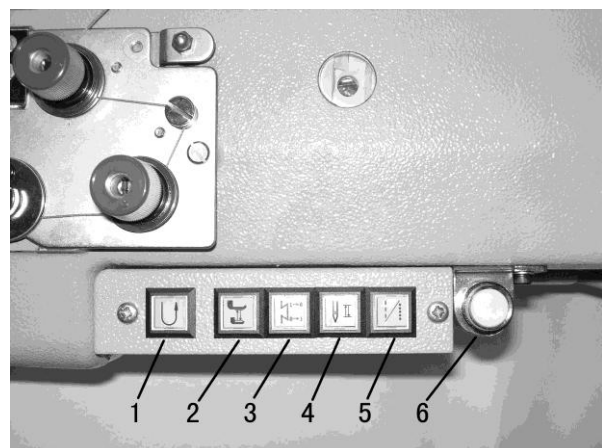

12) Cleaning

- (1) The area around the feed dog and the hook should be cleaned every day.
- (2) Remove any thread scraps from inside the rotary hook.
- (3) Keep the control box clean.

13) Lubrication

- (1) Check the oil level at the sight glass 1 every week. If the oil is not enough, remove oil-filling screw 2 and pour in oil. Check oil level at sight glass 2. The oil level must be between “EMPTY” and “FULL”. Replace oil-filling screw 2. After running for 500 hours since buying the new sewing machine, the oil must be changed. Then change the oil every two years.
- (2) The oil quantity is pre-set at a relatively high level in order to ensure adequate lubrication during running-in. This setting should be checked and corrected after running-in. (approx. 50 hours).

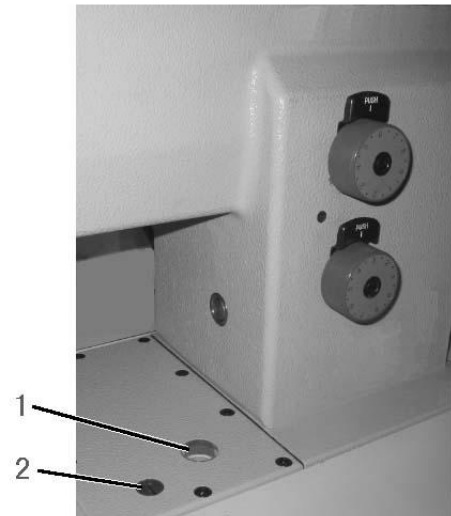

The hook is to have positive lubrication with the least possible amount of oil. Let the sewing machine run approx. 2 minutes. And run in intervals. Hold a piece of paper next to

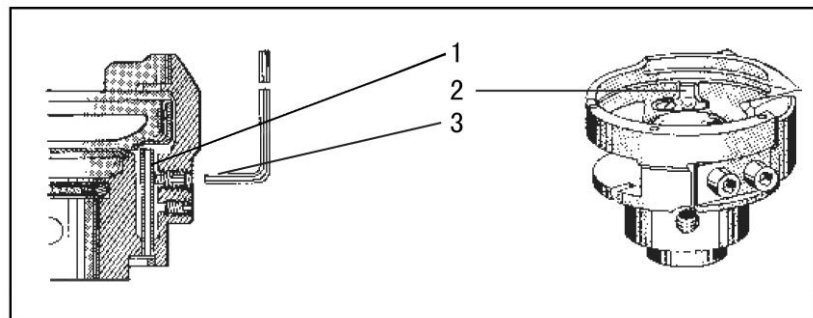

the hook and check if sufficient oil is spun onto the paper. Remove cover plate 2. Loosen screw 3 until the tube 1 no longer moves. This is the case when the tube is in the center of the drilled hole. Turn screw 3 in until the tube movement just starts and then a 1/8 turn farther. The hook lubrication is preset. Attach cover plate 2 again. Setting the hook lubrication with screw 3.

- (3) Lubricating wicks and felt (see the picture of above)

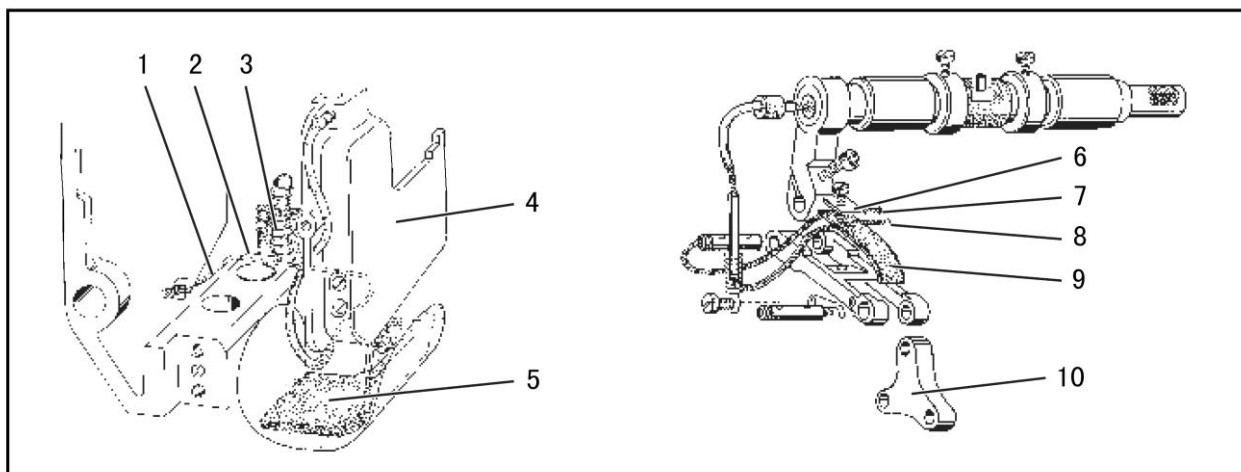

a. The wick 1 leading from the oil sump to the oscillating crank 4 must be fixed between the groove 2 in the arm and the spring 3 of the recirculation wick.

b. When the oil satchel is changed, the flock side should be faced to connecting plate 10. The oil wick 7 and 8 should be set between the oil satchel 9 and plate 8.

(4) Checking the lubrication oil.

Turn on the power switch. Depress the treadle gently and check that the oil level rises in the oil sight glass.

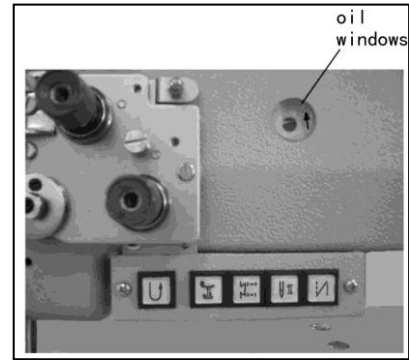

14) Adjusting the trailing length after thread trimming

Adjust by turning the pre-tensioner 1. If the tension of the pre-tension is increased, the lengths of the threads trailing from the needle tips will be reduced; if the tension is reduced, the lengths will be increased.

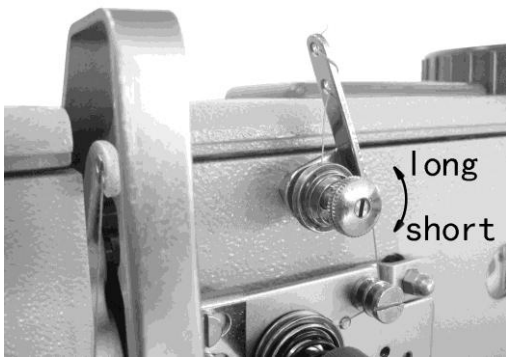

15) Back tacking

When the reverse lever 1 or the quick reverse switch is pressed during sewing, the feed direction will be reversed. When it is released, the feed direction will return to normal.

16) Adjusting the feed dog

Set the feed adjustment dials to the minimum settings. Then adjust as follows so that the feed dog 1 is at its highest position (0.5mm above the top of the needle plate 2) when the needle bar is at its lowest position.

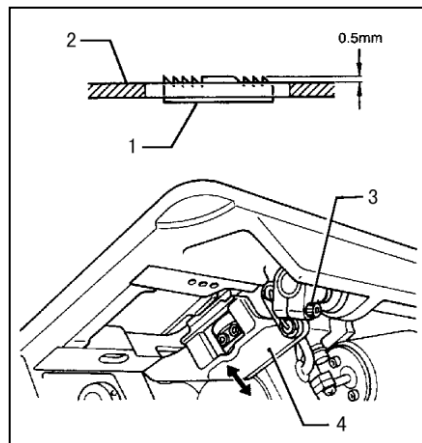

(1) Turn the machine pulley to set the feed dog 1 is at its highest position.

(2) Loosen the screw 3.

(3) Adjust the feed dog's height.

(4) Tighten the screw 3.

17) Adjusting the needle bar height

Set the feed adjustment dials to the minimum settings. Then adjust so that the distance from the setting surface of the needle plate 2 to the end

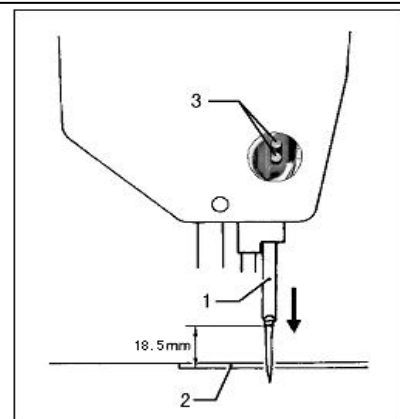

of the needle bar 1 is 18.5mm when the needle bar 1 is at its lowest position.

- (1) Remove the face plate.
- (2) Set the feed adjustment dials to “0”.
- (3) Turn the pulley to set the needle bar 1 to its lowest position.
- (4) Loosen the screw 3 and then move the needle bar 1 up or down to adjust so that the distance from the setting surface of the needle plate 2 to the end of the needle bar 1 is 18.5 mm.
- (5) Tighten the screw 3, install the face plate.

18) Adjusting the gap between the needle and the rotary hook tip

The gap between the needle and the rotary hook tip 1 is 0.1 mm.

Set the rotary hook tip at the level of the middle of the needle. Then adjusting the gap as follow:

- (1) Loosen the screws 2 and 5 (see the picture of below).
- (2) Set the hook base 6 to the fit position.
- (3) Rotate the adjusting plate 3, let the hook base 6 depend on the bed plate 4.
- (4) Tighten the screws 2 and 5.

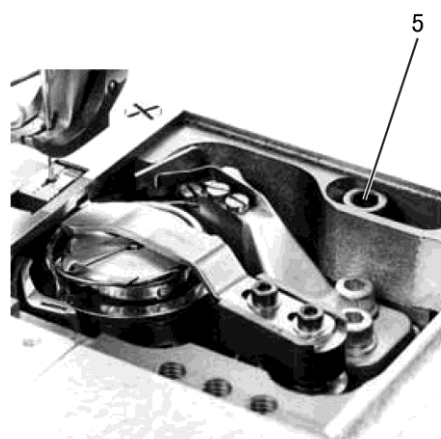
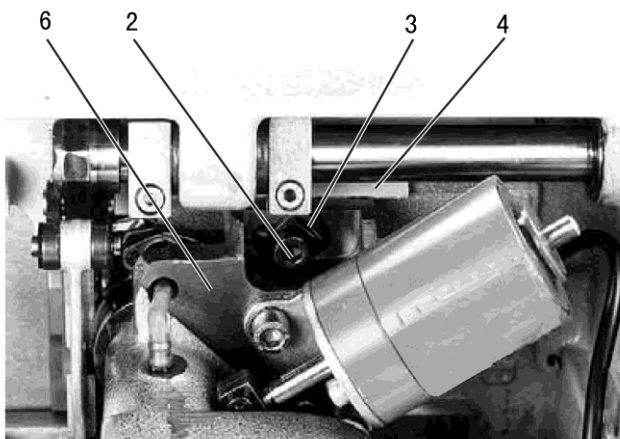
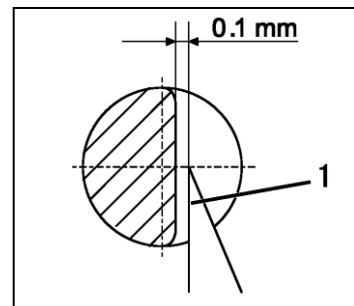

19) Adjusting of the needle and the hook timing

- (1) Set the stitch length to “0”.
- (2) Remove the needle plate.
- (3) Overturn the arm.
- (4) Loosen the screw 1
- (5) Turn the machine pulley to raise the needle bar from its low position to the point that the needle rises 2.4 mm.
- (6) Turn the rotary hook to align the rotary hook tip with the center of the needle.
- (7) Tighten the screw 1.

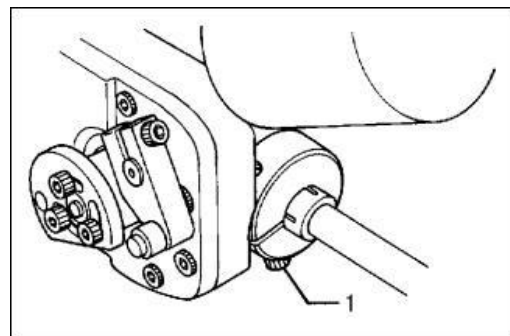

20) Hook protection

In looping stroke position the needle must abut on the hook protection 1 without being displaced.

Move needle in looping stroke position by pulley. In looping stroke position the hook tip is at the level of the middle of the needle. Press needle against hook protection 1 manually. The needle should not touch the hook tip.

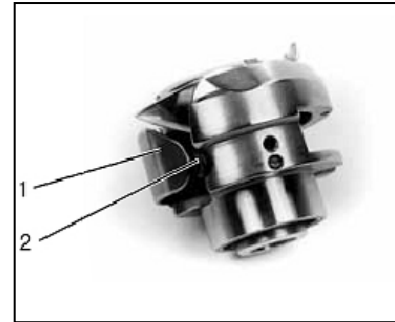

21) Adjusting the needle and feed mechanism timing

(1) Horizontal feed direction

Set the feed adjustment dials to the maximum settings. Then turn the machine pulley until the needle bar is at its lowest position. Then adjust so that the needle and the feed dog do not move even when the reverse lever is moved up and down at this time.

- Remove the bed upper cover 1.
- Set the feed adjustment dial to the maximum settings.
- Loosen the two screws 2.
- Turn the machine pulley until the needle bar is at its lowest position.
- Turn the lower feed cam 3 gradually until it is at the position where the needle and the feed dog do not move even when the reverse lever is moved up and down.
- Tighten the two screws 2.

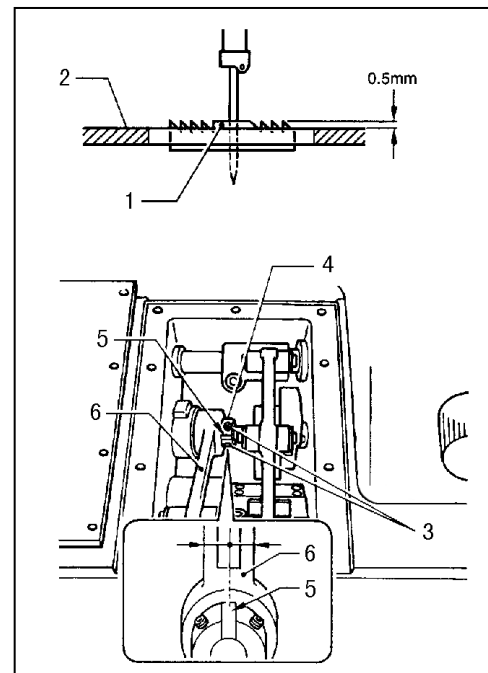

(2) Vertical feed direction

Set the feed adjustment dials to the minimum settings. Then adjust as follows so that the feed dog 1 is at its highest position (0.5mm above the top of the needle plate 2) when the needle bar is at its lowest position.

- Loosen the two screws 3
- Turn the machine pulley to set the needle bar to its lowest position.
- Turn feed cam 4 to align the point 5 of feed cam 4 with the centerline of feed rod 6
- Tighten the screws 3

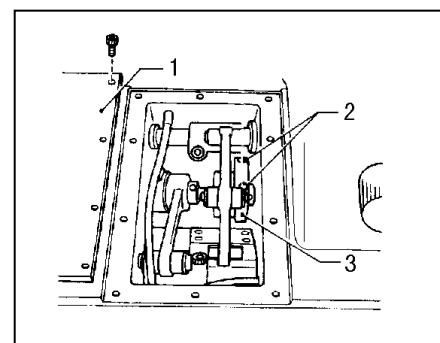

22) Adjusting the opener position

Adjust so that the clearance between the needle plate 3 and the stopper 4 of the inner rotary hook 2 is 0.5-0.7 mm when the opener 1 is at its closest position to the inner rotary hook 2.

- Turn the machine pulley to move the opener 1 in direction “a” (opening direction), and then loosen the

screw 5

(2) Turn the machine pulley to move the opener 1 in direction “b” (closing direction), and then loosen the screw 6.

(3) Turn the machine pulley to move the opener 1 as close to the inner rotary hook 2 as possible.

(4) While pressing the opener 1 against the inner rotary hook 2 with your finger, adjust so that the clearance between the needle plate 3 and the stopper 4 of the inner rotary hook 2 is 0.5-0.7 mm.

(5) Tighten the screw 6.

(6) Turn the machine pulley to move the opener 1 in direction “a” (opening direction), and then tighten the screw 5.

23) Adjusting the presser foot height

The standard height of the outer presser foot 7 is 9 mm when it is raised by the presser lifter bar 1.

(1) Remove the belt cover.

(2) Loosen the presser adjusting screw, to release the presser foot pressure.

(3) Raise the presser lifters bar 1 and then loosen the screw 2.

(4) Move the outer presser bar up or down to adjust so that the height of the outer presser foot 7 is 9 mm.

(5) While the stopper pin 6 is touching against the notch B in the presser foot lifter connection 5 and while pushing the presser lifter shaft so that there is no play in the thrust direction, tighten the screw 2.

(6) Turn the presser adjusting screw to adjust the presser foot pressure.

(7) Install the belt guards.

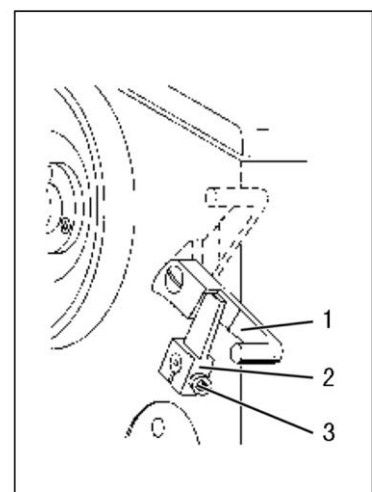
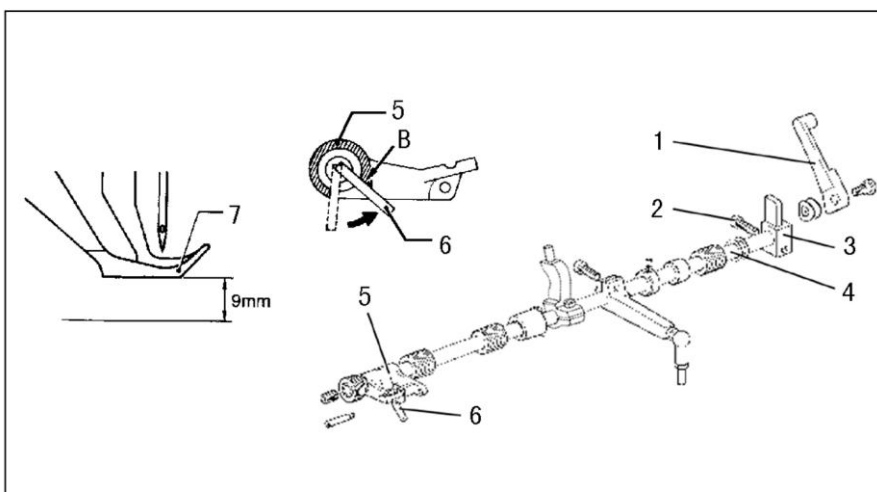
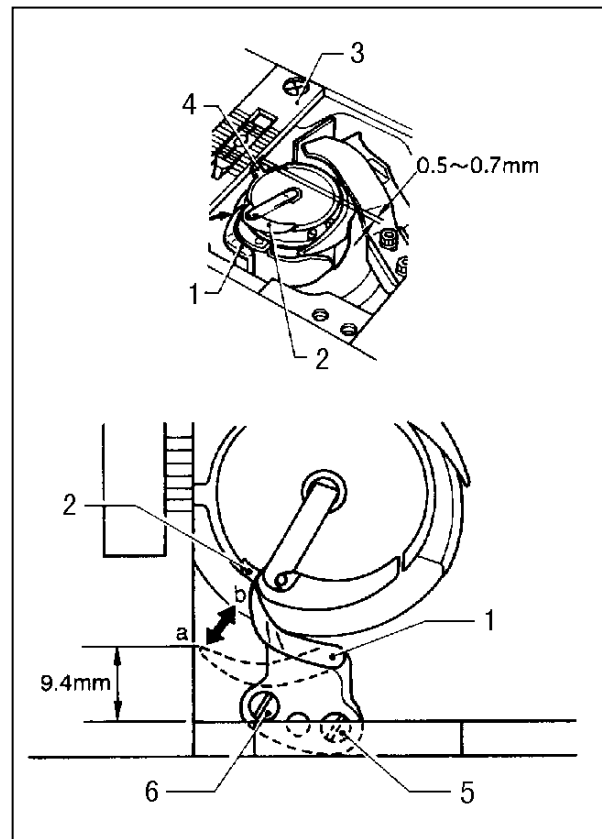

24) Adjusting the alternating presser foot movement amount

(1) Maximum alternating presser foot movement amount. Carry out the following adjustment to set the maximum alternating movement amounts for the inner presser foot 1 and outer presser foot 2 to the maximum of 7 mm.

- a. Remove the upper plate.
- b. Remove the adjusting bracket 3.
- c. Loosen screw 5 of adjusting bracket collar 4.

d. Adjust the adjusting bracket collar 4. If the adjusting bracket collar 4 is be installed at the highest position, the alternating presser foot movement amount is 1-6mm. If it is at the lowest position, the alternating presser foot movement amount is 1.6-7mm.

- e. Tighten the screw 5.
- f. Install the adjusting bracket 3.

d. Loosen the bolt 6 and turn connecting lever 7 to adjust so that the distance from the outer edge of the arm to the outer edge of the pin 7 is 78 mm at this time. Then tighten the bolt 6. (When installing the upper plate, set the alternating presser foot movements dial to the “min.” position.)

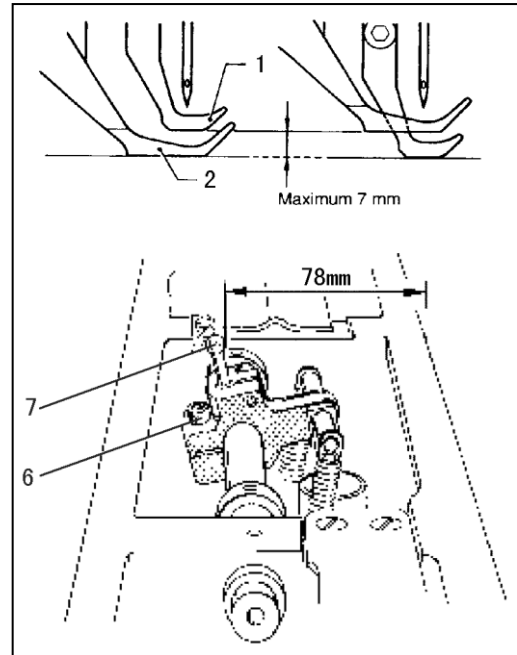

(2) Inner presser foot 1 and outer presser foot 2 movement amounts. Carry out the following adjustment to make the movement amounts for the inner presser foot 1 and outer presser foot 2 equal when the presser feet are lowered and the machine pulley is turned.

- a. Set the feed adjustment dials to the maximum settings.
- b. Open the cover 4
- c. Turn the alternating presser foot movement dial to the “B” position.
- d. Loosen the screw 3

e. Turn the machine pulley toward you to align the tip of the needle and the top of the feed dog with the top of the needle plate.

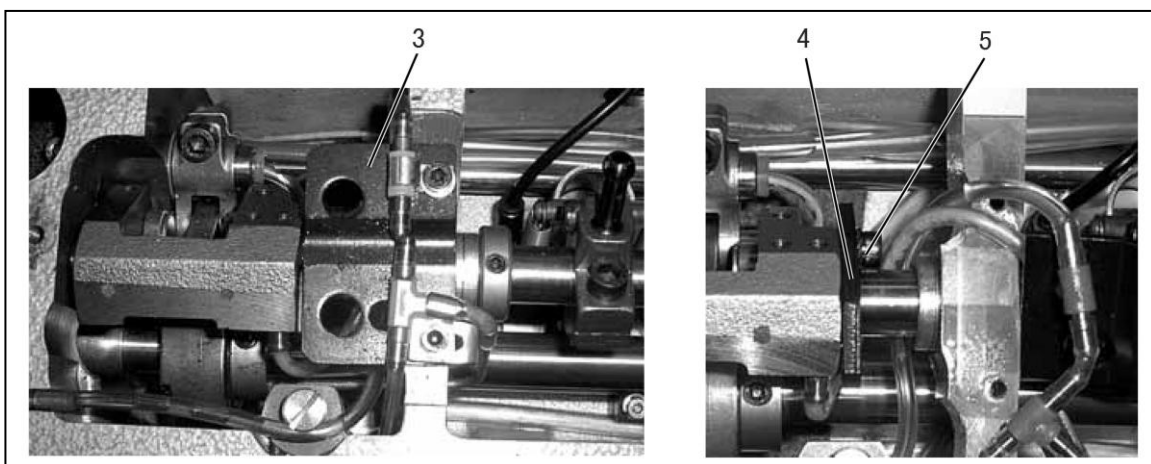

f. Move the connecting lever to adjust so that both the inner presser foot 2 and outer presser foot 1 are in contact with the top of the needle plate at this time. Then tighten the screw 3.

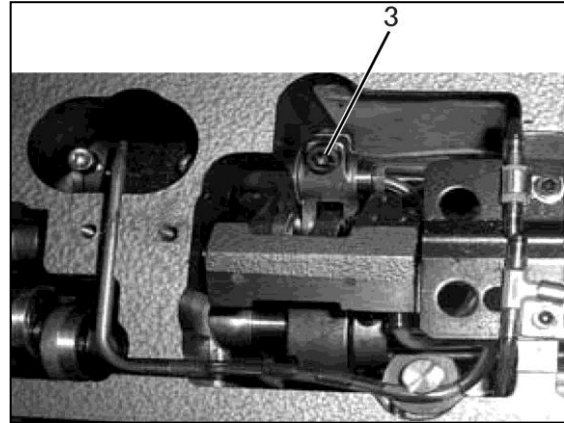
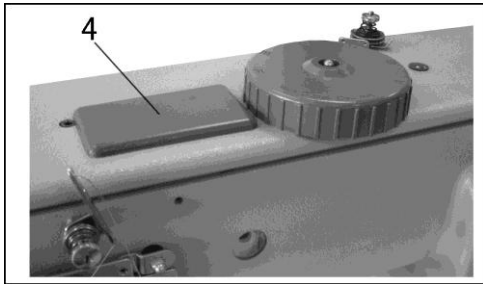

25) Adjusting the presser foot timing

When the presser feet are lowered and the machine pulley is turned toward you. The inner presser foot should touch the feed dog before the needle arrives at the feed dog. Then when the needle lifts up, the tip of the needle should move away from the feed dog before the inner presser foot moves away.

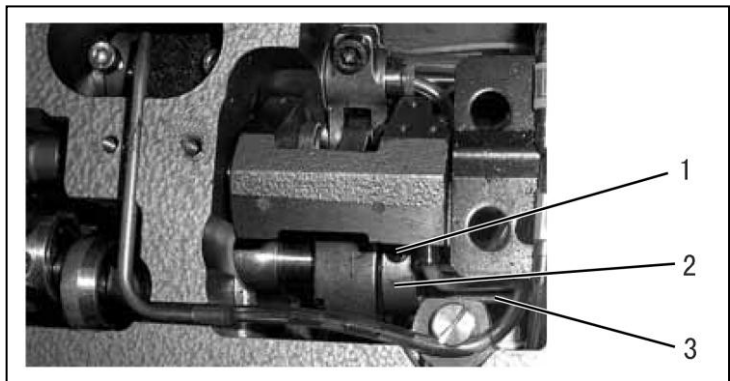

- (1) Remove the upper cover 4.
- (2) Loosen the two screws 1.
- (3) Turn the machine pulley until the needle tip and the feed dog's up face is the same plane.
- (4) Turn inner presser cam 2 to adjust so that the point of inner presser cam 2 is facing straight up.
- (5) Tighten the screws 1.
- (6) Install the upper cover.

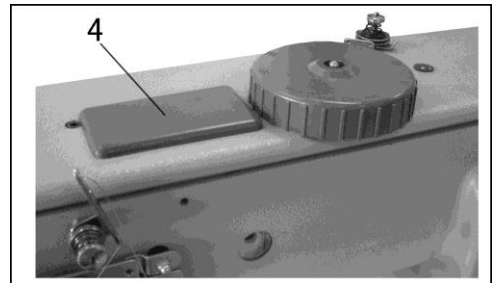

26) Adjusting the fixed knife position

The distance from the groove of slide plate to the fixed knife 1 should be 26 mm. Furthermore, the distance from the edge of the needle plate to the left edge of the tip of the fixed knife 1 should be 4 mm.

- (1) Loosen the two bolts 2.
- (2) Adjust the position of the fixed knife 1, and then tighten the bolts 2.

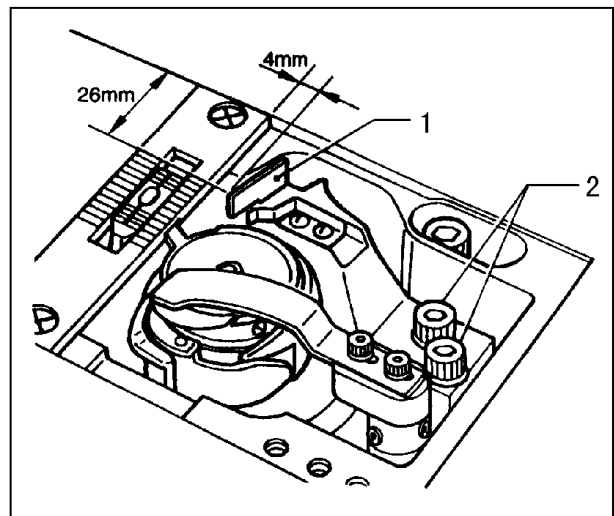

27) Adjusting the thread holding spring position (see the picture of above)

The thread holding spring 1 holds the lower thread after thread trimming to prepare it for the next sewing operation. The clearance between the thread holding spring 1 and the side of the fixed knife 2 should be 1.4-1.6 mm.

- (1) Loosen the two screws 3.
- (2) Move the thread holding spring 1 to adjust its position, and then tighten the screws 3.

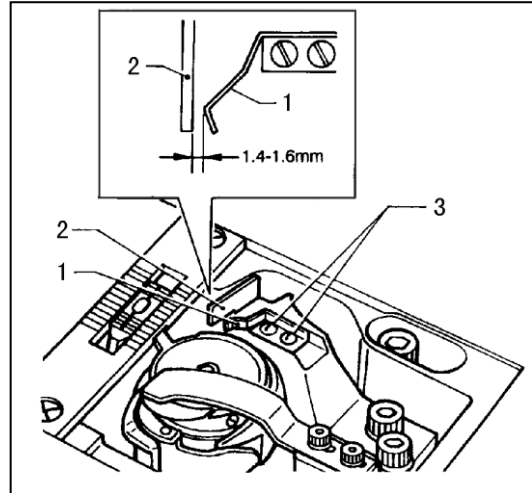

28) Adjusting the knife timing position

After adjusting the position of the fixed knife 1, adjust the knife timing position.

Adjust so that the driving knife 1 starts touching the fixed knife at a position 5.5 mm along the front edge of the driving knife 1.

- (1) Loosen the two bolts 3 and 4.
- (2) Move the driving knife 1 to the left or right to adjust its position.
- (3) Then tighten the bolts 3 and 4.

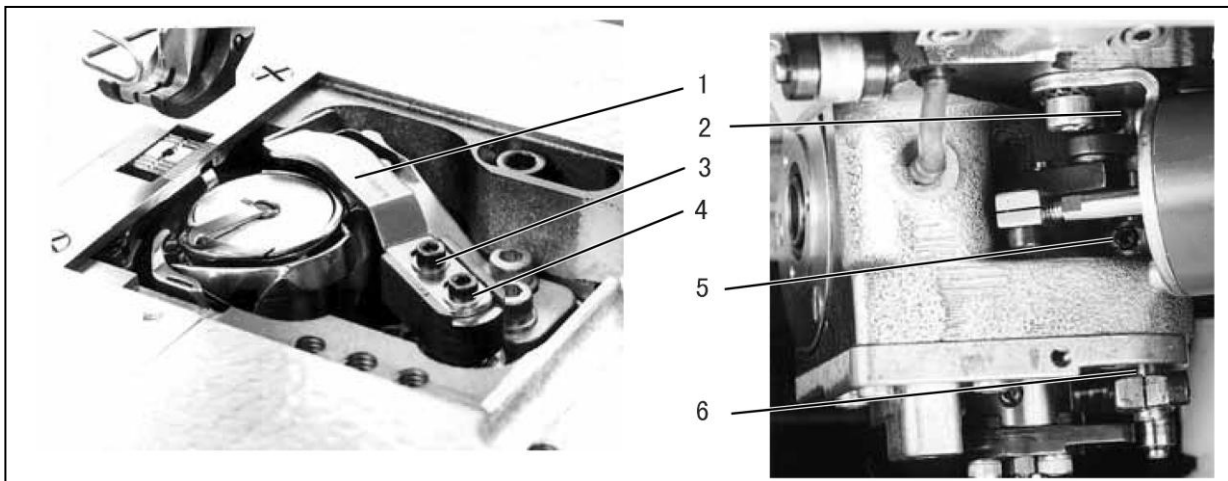

29) Adjusting the driving knife height

The clearance between the lower blade edge of the driving knife 1 and the lower surface of the inner rotary hook should be 0.3-0.4mm. (see the picture on the right)

- (1) Loosen the two screws 2 and 5. (see the picture of above)
- (2) Move the driving knife shaft 6 up or down to adjust the position of the driving knife 1.
- (3) Tighten the screws 2 and 5 on the setting collars again.

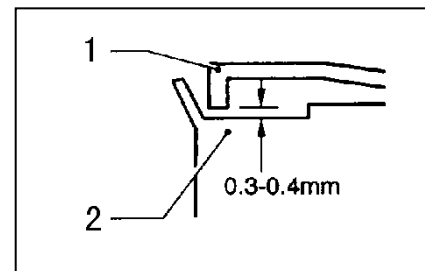

30) Adjusting the driving knife stop position

The distance from the blade of the fixed knife 2 to the end of the driving knife 1 should be 0.5 mm when the driving knife 1 has moved as far as possible toward the fixed knife 2.

(1) Tilt back the machine head.

(2) Turn the machine pulley to move the roller 4 of the driving knife arm 3 to the outermost side (right side) of the thread trimmer cam 5.

(3) Loosen the bolt 6.

(4) Move the driving knife 1 so that the distance between the blade of the fixed knife 2 to the end of the driving knife 1 is 0.5 mm, and then tighten the bolt 6.

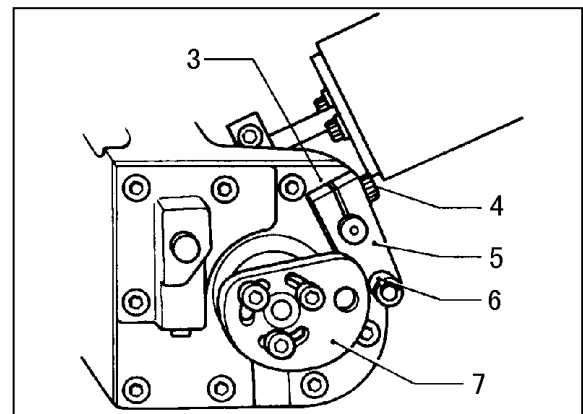
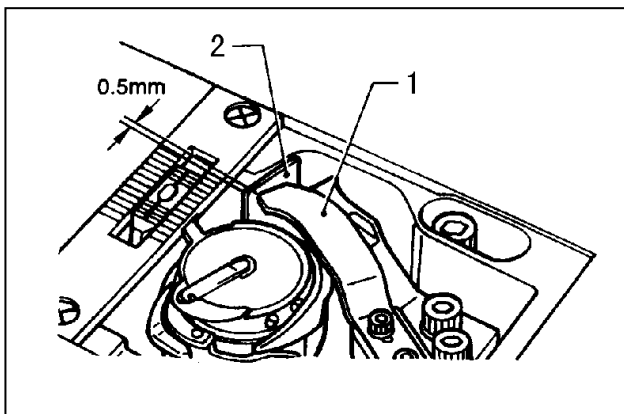

31) Adjusting the driving knife operating position

The standard distance from the left side of driving knife arm 1 to the screw tip on the plunger 2 of the thread trimming solenoid is 1 mm. The clearance between the outermost side (right side) of the thread trimmer cam 5 and the roller 6 of the driving knife arm should be 0.1 mm.

(1) Overturn the arm.

(2) Loosen the bolt 3

(3) Turn the plunger 2 of the thread trimming solenoid so that the distance from the left side of driving knife arm 1 to the screw tip on the plunger 2 of the thread trimming solenoid is 1 mm, and then tighten the bolt 3.

(4) Loosen the bolt 4.

(5) Set the plunger 2 to the position where it projects as far as possible to the left.

(6) Turn the machine pulley to move the roller 6 of the driving knife arm to the outermost side (right side) of the thread trimmer cam 5.

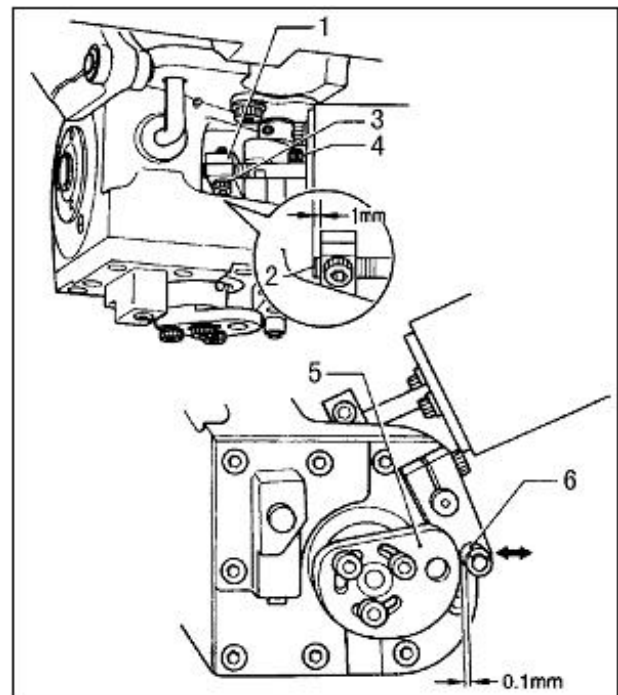

(7) Move the roller 6 so that the clearance between the outermost side (right side) of the thread trimmer cam 5 and the roller 6 is 0.1mm, and then tighten the bolt 4.

32) Adjusting the thread trimming timing

The center of the pin 1, the center of the reference hole 3 and the center of the roller 4 of the driving knife arm should be in a straight line when the thread take-up lever is at the highest position. (The white point on the pulley and the point on the belt cover are in a straight line.)

(1) Turn the machine pulley until the white point on the pulley and the point on the belt cover are in a straight line.

(2) Overturn the arm.

(3) Loosen the three bolts 5

(4) Turn the thread trimmer cam 2 to adjust the position of the thread trimmer cam 2 so that the center of the pin 1, the center of the reference hole 3 and the center of the roller 4 of the driving knife arm are in a straight line.

(5) Tighten the bolts 5.

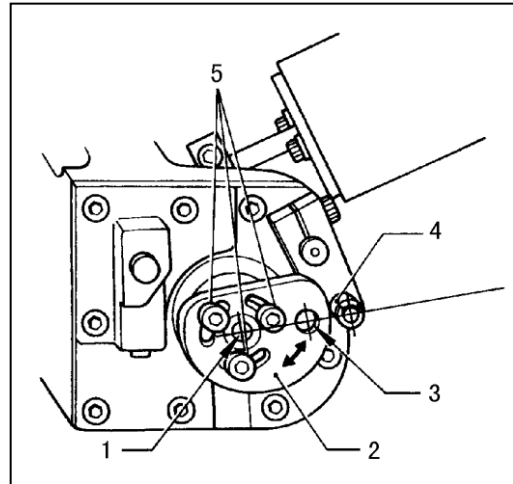

33) Safety clutch

The standard safety clutch 2 in the lower toothed belt wheel protects the hook from being displaced or damaged in case of thread jamming in the hook path. When the hook is blocked, the safety clutch 2 must come out.

(1) Set free blocked hook.

(2) Stick a pin in drill-hole 1 of the outer clutch disc.

(3) Turn the pulley until the pin can be stuck in the drill-holes of both clutch parts.

(4) Turn the pulley forwards and backwards until the hook is freely movable again.

(5) Pull out pin.

(6) Hold down hook and turn the pulley until safety clutch 2 engages.

Adjust transmittable torque

Standard checking

The supplier by means of a torque spanner should adjust the torque transmittable from safety clutch 4.

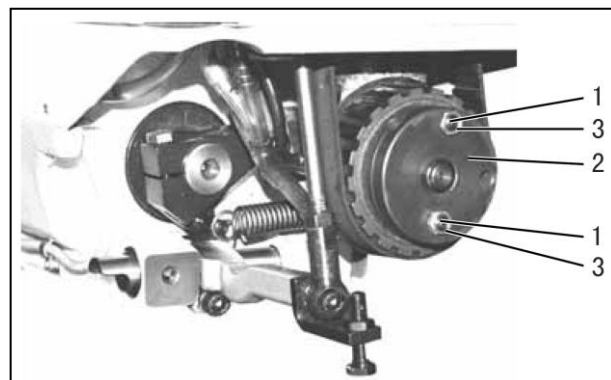
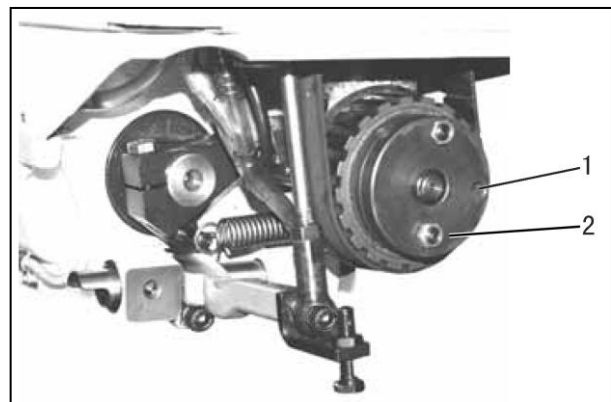

- (1) Loosen counter-nuts 3.
- (2) Adjust torque
- (3) Tighten counter-nuts 3 again.

34) Regulate the atmospheric pressure

When the air cylinder works normally, the necessary atmospheric pressure is 5.5~6.5bar. Can find out through the dial plate of the filtering .

- (1) Lifting knob 1, clockwise rotation , the pressure increases.
- (2)Lifting knob 1, anticlockwise rotation, the pressure is reduced

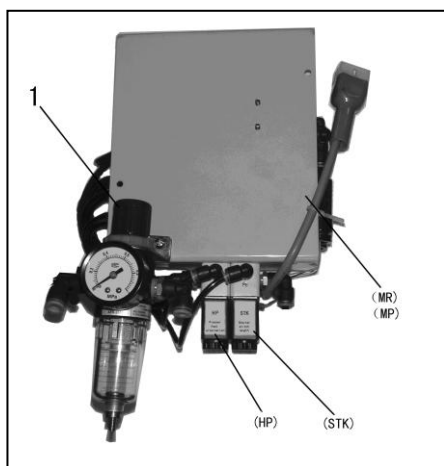

The air pressure of the feed wheel cylinder should between 1~2bar, it can be adjusted by need.

(For filter with regulator)

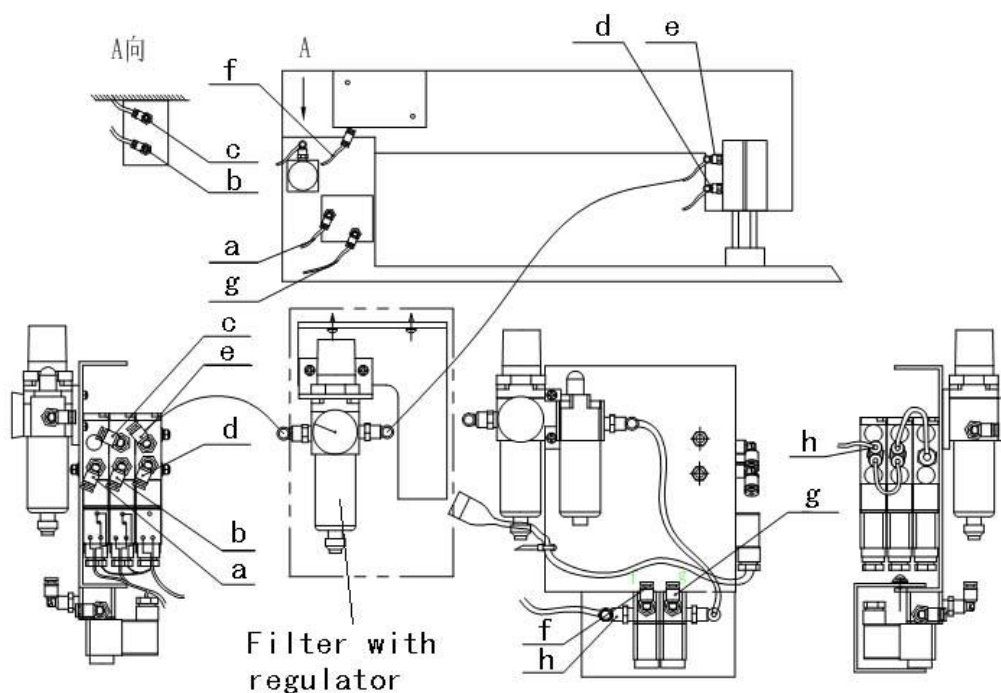

A.ARM BED AND ITS ACCESSORIES

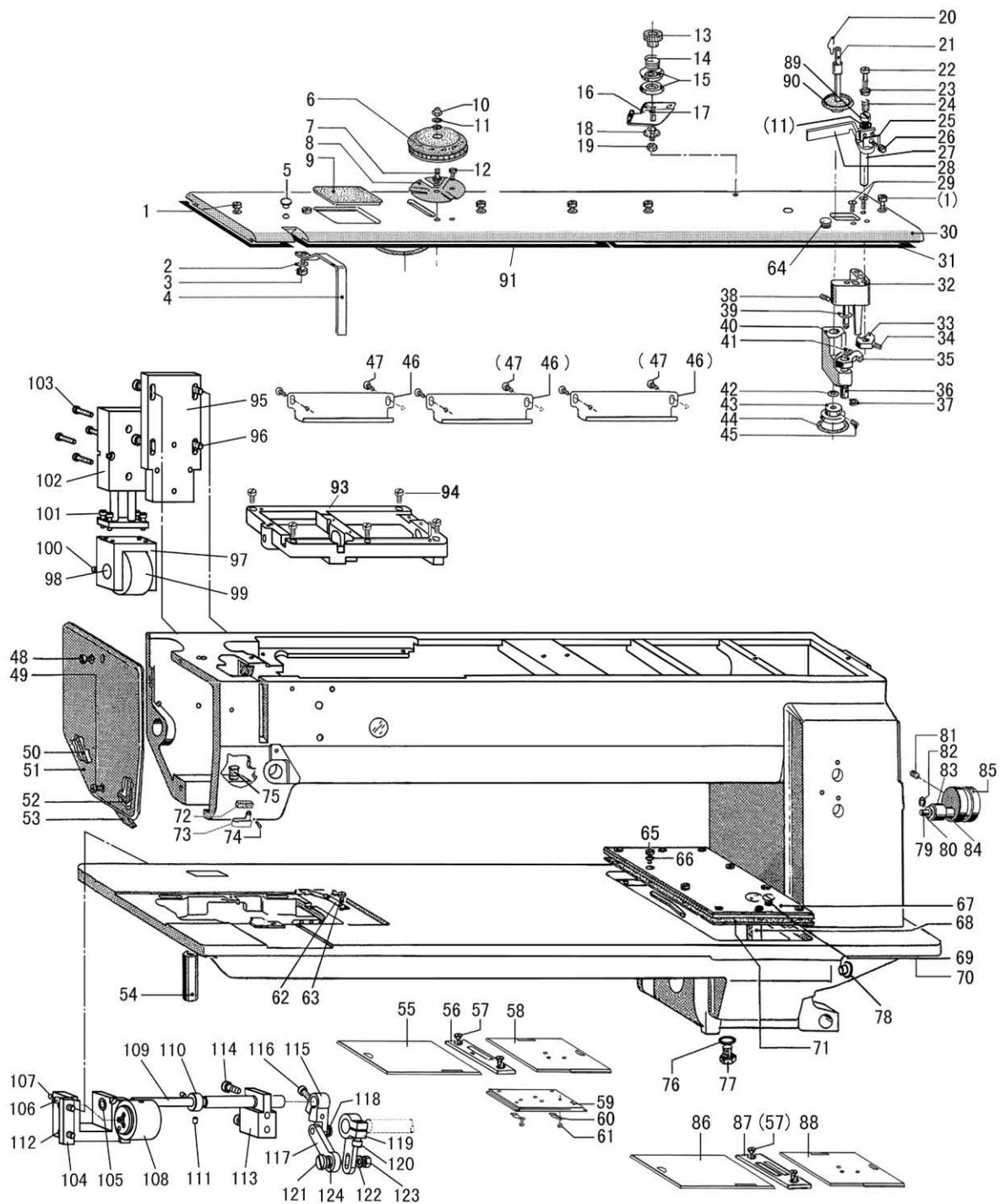

A.ARM BED AND ITS ACCESSORIES

Fig. No.	Part No.	Description	GC20688-1BDL	GC20688-2BDL	Remarks
A01	HF914B8001	Screw M5×12	6	6	
A02	H005001040	Washer	1	1	
A03	H415040080	Screw	1	1	M4×8
A04	HE41B38001	Thread take-up cover	1	1	
A05	HF930B8001	Plug	1	1	
A06	HF933B8001	Dial	1	1	
A07	HF935B8001	Dial shaft	1	1	
A08	HF936B8001	Guard plate	1	1	
A09	HF931B8001	Cover	1	1	
A10	H003024040	Hexagonal nut	1	1	M4
A11	H005001040	Washer	2	2	
A12	H401040060	Screw	1	1	M4×6
A13	HA710B0671	Pre-tension adjusting nut	1	1	
A14	H6739B8001	Thread tension spring	1	1	
A15	HA310B0705	Thread tension discs	2	2	
A16	H6736B8001	Thread guide	1	1	
A17	HF974B8001	Thread tension stud	1	1	
A18	H4728H8001	Washer	1	1	
A19	H5344B8001	Nut	1	1	
A20	HF965B8001	Fixing clamp	1	1	
A21	HF964B8001	Winder shaft	1	1	
A22	H401030120	Screw	1	1	M3×12
A23	HF952B8001	Disc	1	1	
A24	H5731F8001	Presser spring	1	1	
A25	HF954B8001	Knife	1	1	
A26	H401030040	Screw	1	1	M3×4
A27	HF947B7101	Release lever	1	1	
A28	HF949B8001	Winder lever	1	1	M3×12
A29	H403040080	Screw	2	2	M4×8
A30	HE21B58001	Arm cover	1	1	
A31	HE21B68001	Washer	1	1	
A32	HF942B7101	Winder block	1	1	
A33	HF944B8001	Release cam	1	1	
A34	H431050060	Screw	1	1	M5×6
A35	HF958B8001	Block	1	1	
A36	HF956B8001	Bushing	1	1	
A37	H007013035	E-type stop ring 3.5	1	1	
A38	HF961B8001	Presser spring	1	1	
A39	HF957B8001	Washer	1	1	
A40	HF960B8001	Arm	1	1	
A41	HF959B8001	Presser spring	1	1	
A42	HF966B8001	Washer	2	2	
A43	HF967B8001	Winder wheel	1	1	

A.ARM BED AND ITS ACCESSORIES

Fig. No.	Part No.	Description	GC20688-1BDL	GC20688-2BDL	Remarks
A44	H7331D8001	Rubber ring	1	1	
A45	H431050050	Screw	1	1	M5×5
A46	HF999B8001	Cord cover	3	3	
A47	H7331G8001	Screw	6	6	
A48	HF914B8001	Screw M5×12	1	1	
A49	HF915B8001	Screw M5×12	1	1	
A50	HF918B8001	Bar	1	1	
A51	HF913B8001	Face plate	1	1	
A52	HF919B8001	Bar	1	1	
A53	HF920B8001	Oil pillow	1	1	
A54	HF998B8001	Leg	1	1	
A55	HF980B8001	Slide Plate	1		
A56	HF988B8001	Needle plate	1		
A57	HF989B8001	Screw	2	2	
A58	HF981B8001	Slide Plate	1		
A59	HE23B98001	Slide Plate	1	1	
A60	HF986B8001	Spring for slide plate	2	2	
A61	H401020025	Screw	2	2	M2×2.5
A62	HF982B8001	Stopper	1	1	
A63	H7331G8001	Screw	2	2	
A65	HF914B8001	Screw M5×12	10	10	
A66	HF997B8001	Gasket	10	10	
A67	HE22B38001	Cover	1	1	
A68	HF992B8001	Oil indicator	1	1	
A69	HF993B8001	Screw	1	1	
A70	HF994B8001	Gasket	1	1	
A71	HE22B48001	Gasket	1	1	
A72	H3108B0692	Felt	1	1	
A73	H3108B0691	Thread guide	1	1	
A74	HF938C8001	Screw	1	1	
A75	HA307B0674	Rubber plug	1	1	
A76	HF90AB8001	Gasket	2	2	
A77	100010	Screw	1	1	M10×1
A78	HE21I38001	Rubber plug	1	1	
A79	HF981I8001	Pin	1	1	
A80	H7335C8001	Washer	2	2	
A81	H428080120	Screw	1	1	M8×12
A82	H007013060	E-type stop ring 6	1	1	
A83	HF980I8001	Bearing	2	2	
A84	HF980I8001	Spacer	1	1	
A85	HF979I8001	Belt tensioner	1	1	
A86	HG005B8001	Slide Plate		1	
A87	HG007B8001	Needle plate		1	

A.ARM BED AND ITS ACCESSORIES

Fig. No.	Part No.	Description	GC20688-1BDL	GC20688-2BDL	Remarks
A88	HG006B8001	Slide Plate		1	
A89	H415040060	Screw	1	1	
A90	HE41B58001	Bobbin seat	1	1	
A91	HF923B8001	Washer	1	1	
A93	HE21B38001	Setting plate	1	1	
A94	H415050160	Screw	5	5	
A95	HE22B58001	Setting plate	1	1	
A96	H415060160	Screw	4	4	
A97	HE22B78001	Setting plate	1	1	
A98	HE22B88001	Feed shaft	1	1	
A99	HE22B98001	Feed wheel (up)	1	1	
A100	H431050060	Screw	1	1	
A101	H415040160	Screw	4	4	
A102	HE24B27101	Cylinder	1	1	
A103	H415040250	Screw	4	4	
A104	HE23B28001	Setting plate	1	1	
A105	HF805H8001	Bushing	2	2	
A106	HF806H8001	Screw	1	1	
A107	HA100B2110	Screw	1	1	
A108	HE24B37101	Feed wheel	1	1	
A109	HE23B38001	Feed shaft (down)	1	1	
A110	HF821H8001	Collar	1	1	
A111	HA100B2110	Screw	2	2	11/64(40) × 5.5
A112	H415060150	Screw	3	3	
A113	HE23B48001	Setting plate	1	1	
A114	H415060250	Screw	2	2	
A115	HE23B58001	Crack	1	1	
A116	H415050160	Screw	1	1	
A117	HE23B68001	Link	1	1	
A118	H5315E8001	Screw	1	1	
A119	HE23B78001	Crack	1	1	
A120	H3208G0676	Screw	1	1	SM15/64 × 28
A121	HE928J8001	Screw	1	1	
A122	H005005060	Washer	1	1	
A123	H003002060	Nut	1	1	
A124	HA104C0655	Ball bearing	1	1	

B. THREAD TENSION REGULATOR MECHANISM

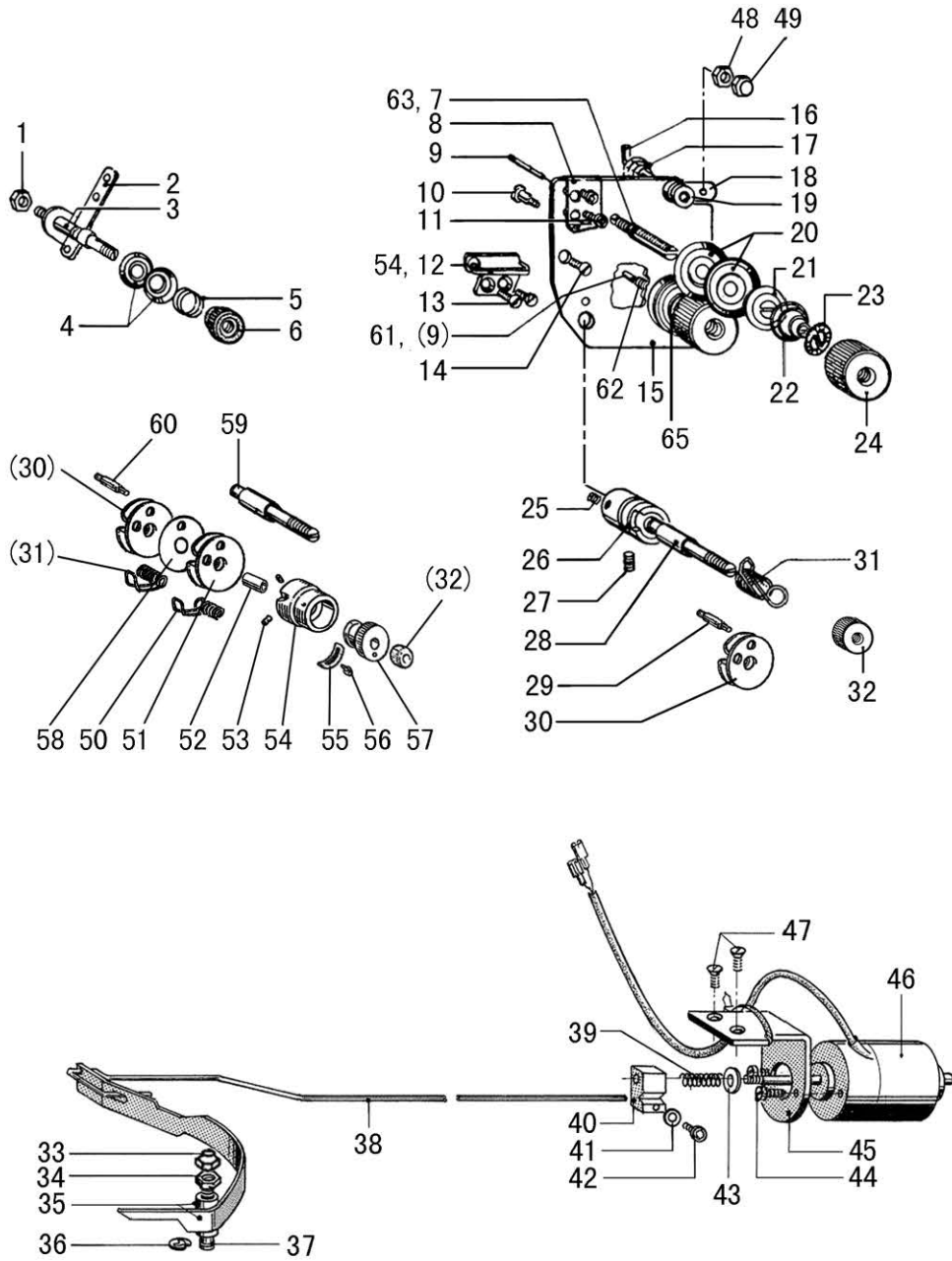

B.THREAD TENSION REGULATOR MECHANISM

Fig. No.	Part No.	Description	GC20688-1BDL	GC20688-2BDL	Remarks
B01	H003002050	Nut	1	2	M5
B02	HF930C8001	Thead hook	1	2	
B03	HF929C8001	Thread tension stud	1	2	
B04	HA112B0693	Thread tension discs	1	2	
B05	HA710B0672	Tension spring	1	2	
B06	HA710B0671	Tension adjusting nut	1	2	
B07	HF907C8001	Thread tension stud	2		
B08	HF917C8001	Thread guide	1	1	
B09	H3221B6817	Thread tension releasing pin	2	1	
B10	H3221B6811	Shoulder screw	2	2	
B11	H7316B8001	Screw	2	2	
B12	HF925C8001	Thread guide	1		
B13	H7322B8001	Screw	2	2	
B14	H7316B8001	Screw	2	2	
B15	HF905C8001	Tension plate	1	1	
B16	HF923C8001	Rod	1	1	
B17	HF924C8001	Sping	1	1	
B18	HF915C8001	Tension release plate	1	1	
B19	HF916C8001	Thread guide	1	1	
B20	HA310B0705	Tension discs	4	4	
B21	HA310B0702	Tension release discs	2	2	
B22	H3300B2040	Tension spring	2	2	
B23	HA115B7010	Stopper	2	2	
B24	HA310B0701	Tension nut	2	2	
B25	H431040040	Screw	1	1	M4×4
B26	HF936C8001	Thread tension post	1	1	
B27	H431050050	Screw	1	1	M5×5
B28	H4805C8001	Thread tension stud	1	1	
B29	H4804C8001	Screw	1	1	
B30	H32481BD21	Plate complete	1	2	
B31	H4713C8001	Thread take-up spring	1	1	
B32	H32481B721	Thumb nut	1	1	
B33	H003045050	Nut	1	1	M5
B34	H003002050	Nut	1	1	M5
B35	HF918C8001	Release lever	1	1	
B36	H007013050	E-type stop ring 5	1	1	
B37	HF919C8001	Bolt	1	1	
B38	HF921C8001	Hook	1	1	
B39	HF908C8001	Spring	1	1	
B40	HF909C8001	Block	1	1	
B41	H005001040	Washer	1	1	
B42	H415040080	Screw	1	2	M4×8
B43	HF927I8001	Washer	1	1	

B.THREAD TENSION REGULATOR MECHANISM

Fig. No.	Part No.	Description	GC20688-1BDL	GC20688-2BDL	Remarks
B44	H415040080	Screw	2	1	M4×8
B45	HF906C8001	Magnet support	1	1	
B46	HE22C28001	Solenoid	1	1	
B47	H403050120	Screw	2	2	M5×12
B48	H003002040	Nut		1	
B49	H003045040	Nut		1	
B50	H4712C8001	Thread take-up spring		1	
B51	H32481BF21	Plate complete		1	
B52	H32481B821	Bushing		1	
B53	H32481B521	Screw		2	
B54	H32481B621	Take-up spring guide		1	
B55	H32481BB21	Stopper		1	
B56	H32481BC21	Screw		1	
B57	H32481B921	Thread tension post		1	
B58	H32481BE21	Plate complete		1	
B59	HG008C8001	Thread tension stud		1	
B60	HG007C8001	Screw		1	
B61	HG009C8001	Tension release discs		1	
B62	H3221B0689	Thread tension stud		1	
B63	H3221B0686	Thread tension stud		1	
B64	HG005C8001	Thread guide		1	
B65	H4710C8001	Tension spring	1	2	

C. NEEDLE BAR AND THREAD TAKE-UP MECHANISM

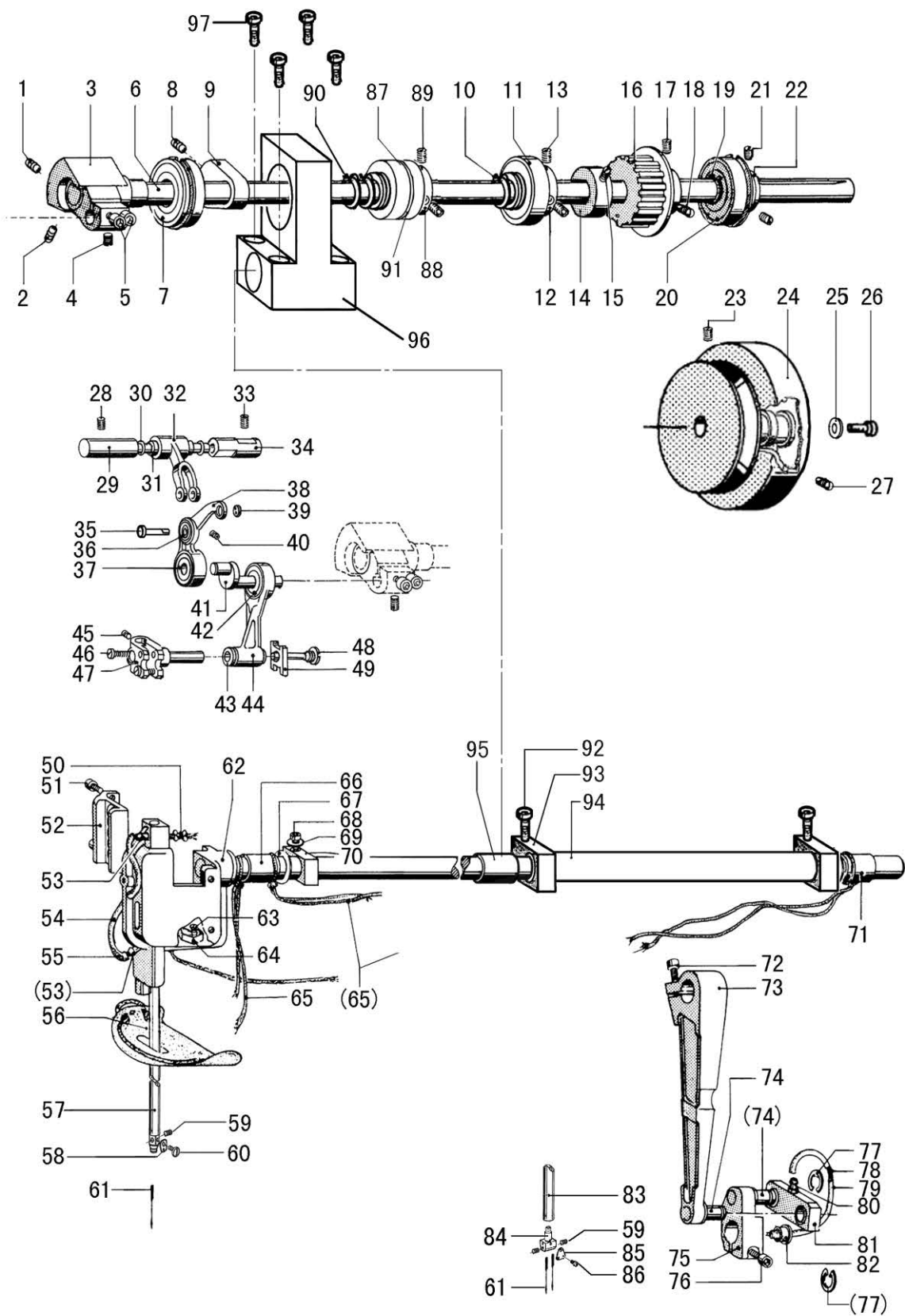

C.NEEDLE BAR AND THREAD TAKE-UP MECHANISM

Fig. No.	Part No.	Description	GC20688-1BDL	GC20688-2BDL	Remarks
C01	H6715C8001	Screw	1	1	
C02	H431060080	Screw	1	1	M6×8
C03	HF907D8001	Crank	1	1	
C04	H431060060	Screw	1	1	M6×6
C05	HF914B8001	Screw	2	2	
C06	HE20D58001	Upper shaft	1	1	
C07	H3205J0662	Ball bearing	1	1	
C08	H431080100	Screw	1	1	M8×10
C09	HF913D8001	Counterweight	1	1	
C10	H007009200	Retainer ring	1	1	
C11	HF921D8001	Ball bearing	1	1	
C12	HF918D8001	Bushing	1	1	
C13	H431060060	Screw	2	2	M6×6
C14	HF943D8001	Bobbin winder driving wheel	1	1	
C15	H431060100	Screw	2	2	M6×10
C16	HF923D8001	Belt pulley (upper)	1	1	
C17	H431060080	Screw	1	1	M6×8
C18	H429060100	Screw	1	1	M6×10
C19	H007009200	Retainer ring	1	1	
C20	HF932D8001	Ball bearing	1	1	
C21	H431060080	Screw	2	2	M6×8
C22	HF929D8001	Bushing	1	1	
C23	H431060100	Screw	1	1	M6×10
C24	HF934D8001	Pulley	1	1	
C25	H005008080	Washer	1	1	
C26	H415080250	Screw	1	1	M8×25
C27	H429060100	Screw	1	1	M6×10
C28	H428050060	Screw	1	1	M5×6
C29	HF913G8001	Thread take-up pin	1	1	
C30	HF918G8001	Gasket	2	2	
C31	H7221G8001	Needle bearing	2	2	
C32	HF916G8001	Thread take-up support	1	1	
C33	H428050120	Screw	1	1	M5×6
C34	HF911G8001	Thread take-up pin bushing	1	1	
C35	HF919G8001	Support screw	1	1	
C36	HF909G8001	Bearing	1	1	
C37	H6722I8001	Bearing	1	1	
C38	HE40G78001	Thread take-up lever	1	1	
C39	HF908G8001	Bushing	1	1	
C40	H431030040	Nut	1	1	M3
C41	HF920G8001	Thread take-up crank	1	1	
C42	HF923G8001	Bearing	2	2	
C43	HF926G8001	Bushing	1	1	

C.NEEDLE BAR AND THREAD TAKE-UP MECHANISM

Fig. No.	Part No.	Description	GC20688-1BDL	GC20688-2BDL	Remarks
C44	HF922G8001	Needle bar link	1	1	
C45	H431030050	Screw	1	1	M3×5
C46	H401040100	Screw	2	2	M4×10
C47	HF924G8001	Needle bar holder	1	1	
C48	HF928G8001	Threaded bolt	1	1	
C49	HF927G8001	Slide block	1	1	
C50	HF938G8001	Oil wick	1	1	
C51	H415040100	Screw	2	2	M4×10
C52	HF933G8001	Slide guide	1	1	
C53	HF939G8001	Oil feeding pipe	2	2	
C54	HF936G8001	Oil pipe	1	1	
C55	HF937G8001	Oil wick	1	1	
C56	HF940G7101	Rubber	1	1	
C57	HE21G58001	Needle bar	1	1	
C58	HF971G8001	Thread guide	1	1	
C59	H402030040	Screw	1	2	M3×3
C60	HF972G8001	Screw	1	1	
C61	JZDP1700G230	Needle	1	2	DP×17 #23
C62	HE20G97101	Needle bar bracket	1	1	
C63	H403040100	Screw	1	1	M4×10
C64	HF943G8001	Oil satchel	1	1	
C65	HF947G8001	Oil wick	3	3	
C66	HF927E8001	Bushing	1	1	
C67	HF968G8001	Support disc	2	2	
C68	H415040120	Screw	2	2	M4×12
C69	H005001040	Washer	2	2	
C70	HF965G8001	Collar	2	2	
C71	HF924E8001	Bushing	1	1	
C72	H415060200	Screw	1	1	M6×20
C73	HE21G38001	Upper feed connecting rod	1	1	
C74	HF951G8001	Shoulder screw	1	1	
C75	HF949G8001	Connecting lever	1	1	
C76	H415060160	Screw	1	1	M6×16
C77	H007013080	E-type stop ring 8	2	2	
C78	HF958G8001	Oil wick	1	1	
C79	HF957G8001	Oil pipe	1	1	
C80	HF956G8001	Oil feeding pipe	1	1	
C81	HF952G7101	Pull rod	1	1	
C82	HF959G8001	Plug	1	1	
C83	HE30G58001	needle bar		1	
C84	HG006G8001	needle bar connecting stud		1	
C85	HG007G8001	Thread guide		1	
C86	HG008G8001	Screw		1	

C.NEEDLE BAR AND THREAD TAKE-UP MECHANISM

Fig. No.	Part No.	Description	GC20688-1BDL	GC20688-2BDL	Remarks
C87	HG608C8001	Bearing	2	2	6804 ZZNR/5K 20×32×7
C88	HF918D8001	Bushing	1	1	
C89	H431060060	Screw	2	2	
C90	H007009200	Retainer ring	1	1	
C91	H9108D8001	Washer	1	1	
C95	HF924E8001	Bushing	1	1	
C96	HE22B18001	Bearing setting plate	1	1	
C97	H415060250	Screw	4	4	

D.PRESSER FOOT MECHANISM

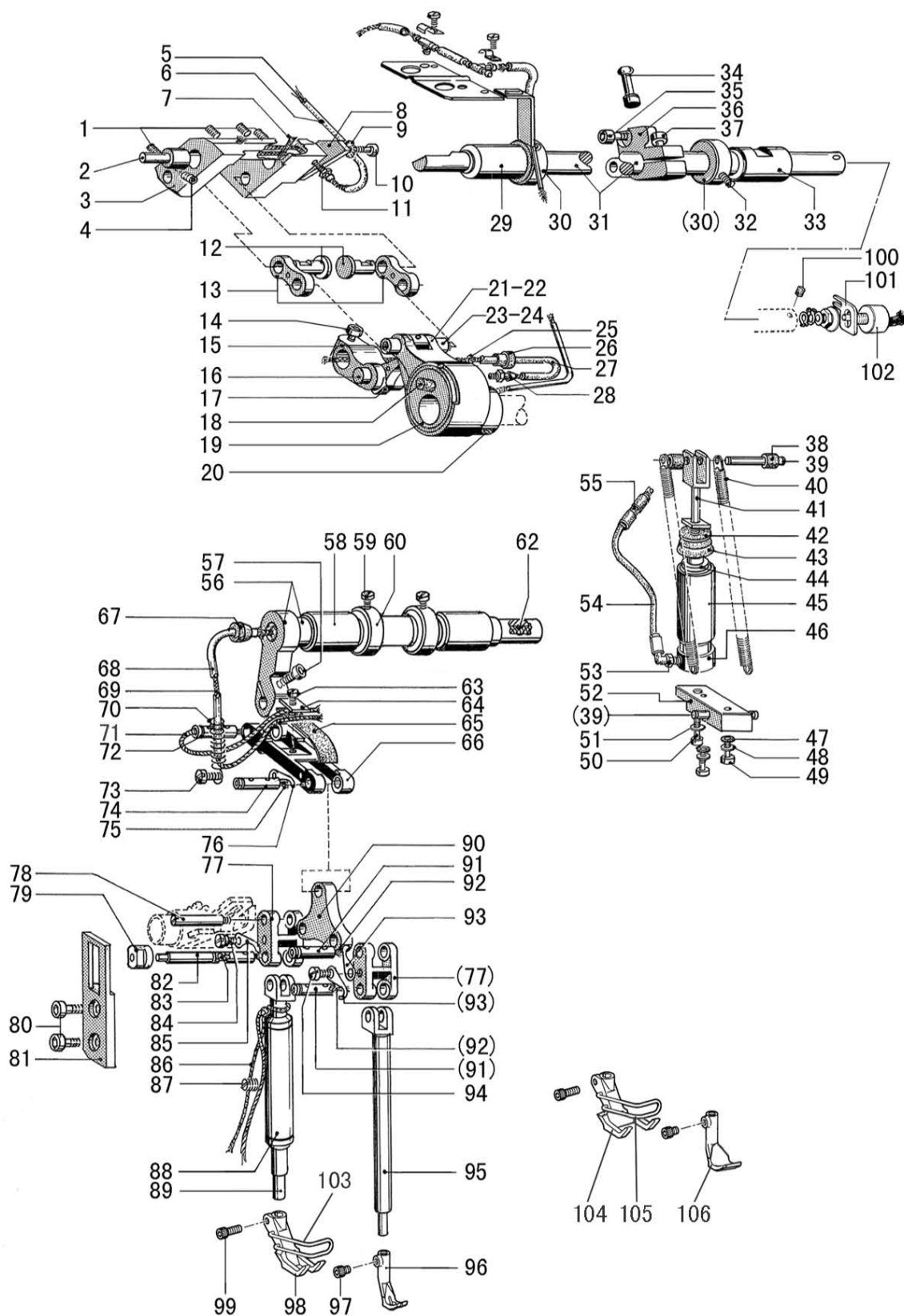

D.PRESSER FOOT MECHANISM

Fig. No.	Part No.	Description	GC20688-1BDL	GC20688-2BDL	Remarks
D01	H428050080	Screw	4	4	
D02	HF919E8001	Support pin	1	1	
D03	HF906E8001	Adjusting bracket	1	1	
D04	H428050080	Screw	1	1	
D05	HF912E8001	Oil wick	1	1	
D06	HF911E8001	Oil pipe	1	1	
D07	HF908E8001	Oil wick	2	2	
D08	HF913E8001	Plate	1	1	
D09	H005018050	Washer	1	1	
D10	H415050100	Screw	1	1	
D11	HF956G8001	Oil feeding pipe	1	1	
D12	HF917E8001	Link pin	2	2	
D13	HF916E8001	Link	2	2	
D14	H415060200	Screw	1	1	
D15	HF951E8001	Connecting lever	1	1	
D16	HF956E8001	Pin	1	1	
D17	HF953E7101	Link	1	1	
D18	HA104D0652	Plug	1	1	
D19	HF942E8001	Inner presser cam	1	1	
D20	H428060060	Screw	2	2	
D21	HF946E8001	Inner presser rod	1	1	
D22	HF947E8001	Bearing	1	1	
D23	HF948E8001	Rod pin	1	1	
D24	HF949E8001	Oil wick	1	1	
D25	HF960E8001	Oil wick	1	1	
D26	HF961E8001	Plug	1	1	
D27	HF959E8001	Oil pipe	1	1	
D28	HF956G8001	Oil feeding pipe	1	1	
D29	HF924E8001	Bushing	1	1	
D30	HF923E8001	Collar	2	2	
D31	HF921E8001	Adjusting shaft	1	1	
D32	H431050050	Screw	2	2	
D33	HF927E8001	Bushing	1	1	
D34	HF928E8001	Ball pin	1	1	
D35	H415050120	Screw	1	1	
D36	HF926E8001	Lever	1	1	
D37	H415060200	Screw	1	1	
D38	HF940E8001	Pipe	2	2	
D39	HF914E8001	Pin	2	2	
D40	HF918E8001	Spring	2	2	
D41	HF933E8001	Draught rod	1	1	
D42	HF936E8001	Disc	1	1	
D43	HF935E8001	Gasket	1	1	

D.PRESSER FOOT MECHANISM

Fig. No.	Part No.	Description	GC20688-1BDL	GC20688-2BDL	Remarks
D44	HF934E8001	Piston	1	1	
D45	HF931E8001	Pipe	1	1	
D46	HF932E8001	Cylinder base	1	1	
D47	HF997B8001	Gasket	2	2	
D48	H005001050	Washer	2	2	
D49	H415050180	Screw	2	2	
D50	H415040160	Screw	1	1	
D51	H005001040	Washer	1	1	
D52	HF943E8001	Spacer	1	1	
D53	HF937E8001	Coupling	1	1	
D54	HF938E8001	Hose	1	1	
D55	HF939E8001	Coupling	1	1	
D56	HF962E7101	Shaft	1	1	
D57	H415040120	Screw	1	1	
D58	HF924E8001	Bushing	2	2	
D59	H402050080	Screw	2	2	
D60	HF923E8001	Collar	2	2	
D61	HF970E8001	Sponge	1	1	
D62	HF964E8001	Oil wick	1	1	
D63	H415030060	Screw	1	1	
D64	HF974E8001	Plate	1	1	
D65	HF973E8001	Oil satchel	1	1	
D66	HF972E8001	Draught rod	1	1	
D67	HF961E8001	Plug	1	1	
D68	HF983E8001	Oil pipe	1	1	
D69	HF984E8001	Oil wick	1	1	
D70	HF982E8001	Spring	1	1	
D71	HF986E8001	Oil wick	1	1	
D72	HF977E8001	Pin	1	1	
D73	H401040040	Screw	1	1	
D74	HF977E8001	Pin	1	1	
D75	HF978E8001	Oil wick	1	1	
D76	HF979E8001	Stopper claw	1	1	
D77	HF925F8001	Joint	1	1	
D78	HF926F8001	Pin	1	1	
D79	HF933F8001	Slide block	1	1	
D80	HF914B8001	Screw	2	2	
D81	HF934F8001	Guide	1	1	
D82	HF928F8001	Pin	1	1	
D83	HF930F8001	Oil wick	1	1	
D84	HF932F8001	Screw	1	1	
D85	HF979E8001	Stopper claw	1	1	
D86	HF939F8001	Oil wick	1	1	

D.PRESSER FOOT MECHANISM

Fig. No.	Part No.	Description	GC20688-1BDL	GC20688-2BDL	Remarks
D87	H431050100	Screw	1	1	
D88	HF940F8001	Bushing	1	1	
D89	HE20F58001	Outer presser bar	1	1	
D90	HF946F8001	Presser connecting plate	1	1	
D91	HF977E8001	Connecting pin	2	2	
D92	HF978E8001	Oil wick	2	2	
D93	HF979E8001	Stopper claw	2	2	
D94	H401040040	Screw	1	1	M5×10
D95	HE20F68001	Inner presser bar	1	1	
D96	HF959F8001	Inner presser foot	1		
D97	HF960F8001	Screw	1	1	
D98	HF943F8001	Outer presser foot	1		
D99	HF944F8001	Screw	1	1	
D100	H431040040	Screw	1	1	
D101	HF987E8001	Holder	1	1	M4×4
D102	HF922E8001	Potentiometer control	1	1	
D103	HF945F8001	Finger gusrd		1	
D104	HG005F8001	Outer presser foot		1	
D105	HG006F8001	Finger gusrd		1	
D106	HG008F8001	Inner presser foot		1	M4×10

E. UPPER FEED LIFTING ROCK SHAFT MECHANISM

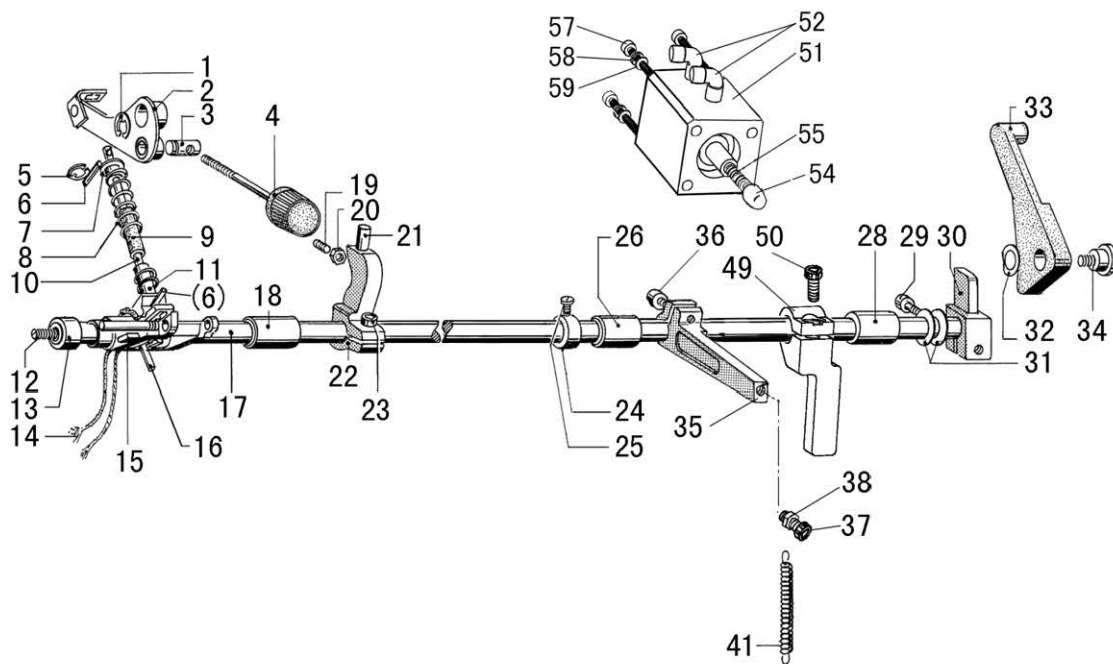

E.UPPER FEED LIFTING ROCK SHAFT MECHANISM

Fig. No.	Part No.	Description	GC20688-1BDL	GC20688-2BDL	Remarks
E01	H007013080	E-type retaining ring 8	1	1	
E02	HF965F7101	Press adjusting plate assy	1	1	
E03	HF963F8001	Pin	1	1	
E04	HF961F7101	Press adjusting dial	1	1	
E05	H007013050	E-type retaining ring 5	1	1	
E06	H609030080	Spring pin	2	2	
E07	HF976F8001	Spring support (U)	1	1	
E08	HF972F8001	Spring	1	1	
E09	HF975F8001	Hose	1	1	
E10	HF973F8001	Shaft	1	1	
E11	HF974F8001	Spring support (D)	1	1	
E12	H428080120	Bolt	1	1	M8×12
E13	HF905F8001	Press-foot lifter shaft bush(L)	1	1	
E14	HF922F8001	Oil wick	1	1	
E15	HF919F7101	Press-foot lifter connection assy	1	1	
E16	H605050320	Pin	1	1	
E17	HE20F48001	Press bar lifter shaft	1	1	
E18	HF906F8001	Spreader shaft bush(L2)	1	1	
E19	H424050160	Set screw	1	1	
E20	H003002050	Nut	1	1	
E21	HF997F8001	Stopper	1	1	
E22	HF996F8001	Crack	1	1	
E23	H415060160	Screw	1	1	M6×16
E24	HF910F8001	Set screw collar	1	1	
E25	H401050060	Screw	1	1	
E26	HF908F8001	Bushing(R2)	1	1	
E28	HF907F8001	Bushing(R)	1	1	
E29	H415060200	Screw	1	1	M6×20
E30	HF913F8001	Crack	1	1	
E31	HF915F8001	Washer	2	2	
E32	H005014080	Wave washer	1	1	
E33	HF916F8001	Lifter lever	1	1	
E34	HF917F8001	Screw	1	1	
E35	HF980F8001	Lever(U)	1	1	
E36	H415060160	Screw	1	1	M6×16
E37	H415050180	Screw	1	1	M5×25
E38	H003002050	Nut	1	1	M5
E41	HF982F8001	Main spring	1	1	
E49	HF901F8001	Crack	1	1	
E50	H415060160	Screw	1	1	
E51	HF911F8001	Pump	1	1	SDA32×20
E52	HF912M8001	Windpipe joint	2	2	EPL4-01 φ 4-1/8"
E54	HF91BF8001	Coupling	1	1	

E.UPPER FEED LIFTING ROCK SHAFT MECHANISM

Fig. No.	Part No.	Description	GC20688-1BDL	GC20688-2BDL	Remarks
E55	H428060160	Screw	1	1	
E57	H415040550	Screw	4	4	
E58	H005008040	Spring washer	4	4	
E59	H005004040	Washer	4	4	

F.STITCH REGULATOR MECHANISM

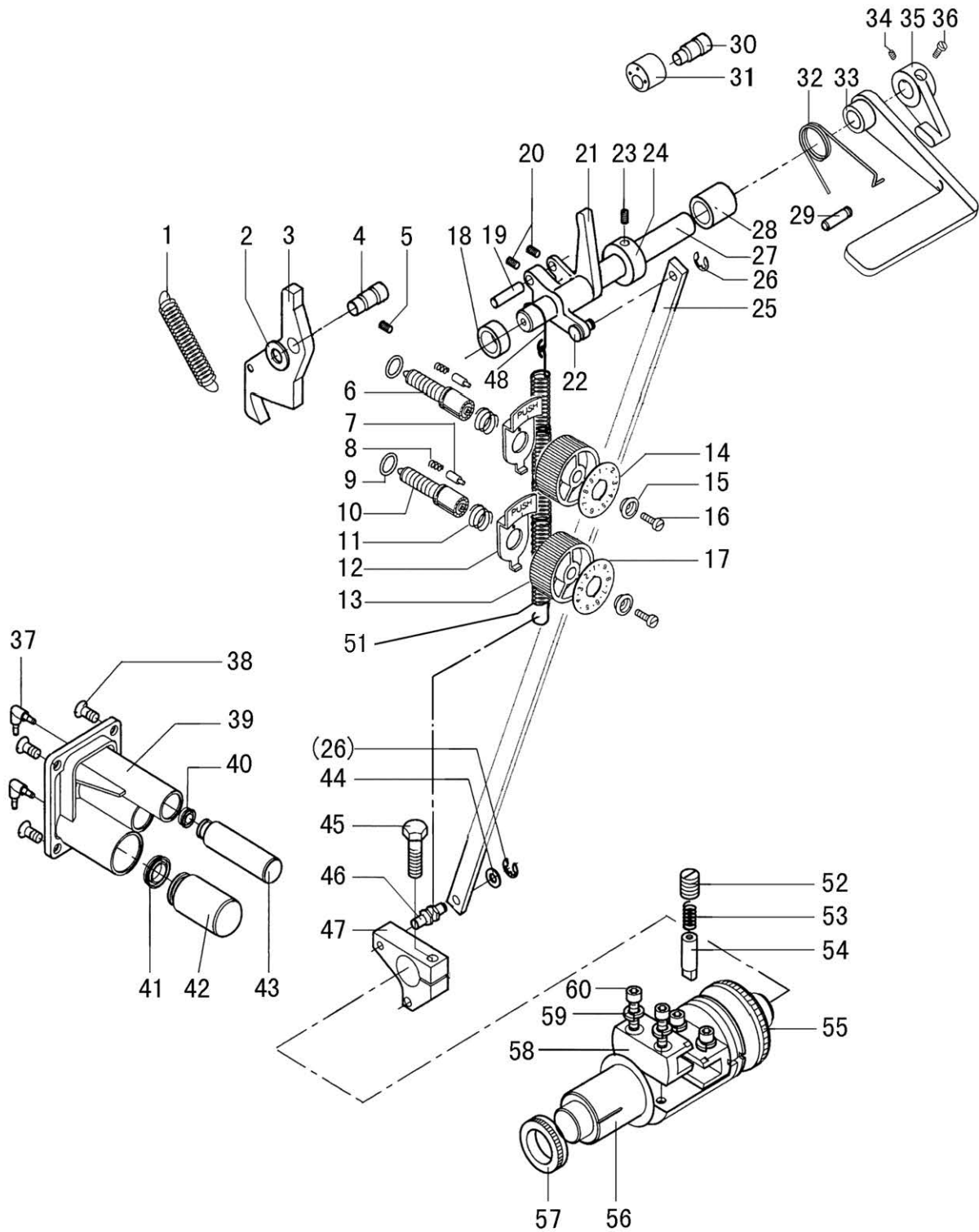

F.STITCH REGULATOR MECHANISM

Fig. No.	Part No.	Description	GC20688-1BDL	GC20688-2BDL	Remarks
F01	HF925H8001	Spring	1	1	
F02	HF924H8001	Washer	1	1	
F03	HF922H8001	Feed adjusting arm	1	1	
F04	HF923H8001	Pin	1	1	
F05	H431050080	Bolt	1	1	M5×8
F06	HF914H8001	Feed adjusting screw (long)	1	1	
F07	HA700F2030	Positioning pin	2	2	
F08	H3200F2110	Spring	2	2	
F09	HA109F0674	O ring	2	2	
F10	HF914H8001	Feed adjusting screw (short)	1	1	
F11	HA720F0687	Spring	2	2	
F12	HA720F0683	Support plate	2	2	
F13	HA7421F120	Feed adjusting dial	2	2	
F14	HF909H8001	Feed adjusting dial plate(L)	1	1	
F15	HA720F0685	Bushing	2	2	
F16	HA720F0686	Screw	2	2	
F17	HF918H8001	Feed adjusting dial plate(S)	1	1	
F18	HF928H8001	Reverse shaft bushing(L)	1	1	
F19	HF932H8001	Pin	1	1	
F20	H428060080	Bolt	2	2	M6×8
F21	HF930H8001	Reverse stitching arm(U)	1	1	
F22	HF934H8001	Pin	1	1	
F23	H428060060	Bolt	1	1	M6×6
F24	HF927H8001	Collar	1	1	
F25	HE20H48001	Rod	1	1	
F26	H007013050	E-tpye retaining ring 5	2	2	
F27	HF970H8001	Reverse stitching shaft	1	1	
F28	HF931H8001	Reverse shaft bushing(R)	1	1	
F29	H6511H8001	Pin	1	1	
F30	H4937L8001	Bolt	1	1	
F31	H4938L8001	Rubber ring	1	1	
F32	HF969H8001	Spring	1	1	
F33	HF968H8001	Reverse stitching lever	1	1	
F34	HA3411D308	Bolt	1	1	
F35	H4936L8001	Reverse stitching lever block	1	1	
F36	HA113F0684	Bolt	1	1	
F37	HF937E8001	Coupling	2	2	
F38	H403060120	Screw	4	4	M6×10
F39	HF947H8001	Pump	1	1	
F40	HF954H8002	Ring	1	1	
F41	HF951H8001	Ring	1	1	
F42	HF950H8001	Piston	1	1	
F43	HF953H8001	Piston	1	1	

F.STITCH REGULATOR MECHANISM

Fig. No.	Part No.	Description	GC20688-1BDL	GC20688-2BDL	Remarks
F44	H005001060	Washer	1	1	
F45	H104060250	Screw(D)	1	1	M6×25
F46	HF939H8001	Bolt	1	1	
F47	HF937H8001	Reverse stitching arm(D)	1	1	
F48	HF974H8001	S shaped hook	1	1	
F51	HE20H78001	Pull spring	1	1	
F52	H424100100	Thread pin	1	1	M10×10
F53	H3100D2090	Presser spring	1	1	
F54	HF963H8001	Key	1	1	
F55	HF966H8001	Oil seal	1	1	
F56	HF958H8001	Shaft	1	1	
F57	HF967H8001	Oil seal	1	1	
F58	HF961H8001	Guide	2	2	
F59	H005009050	Elastic washer	4	4	
F60	H415050160	Screw	4	4	M5×16

G.FEEDING AND FEED LIFTING & ROTATING HOOK SHAFT MECHANISM

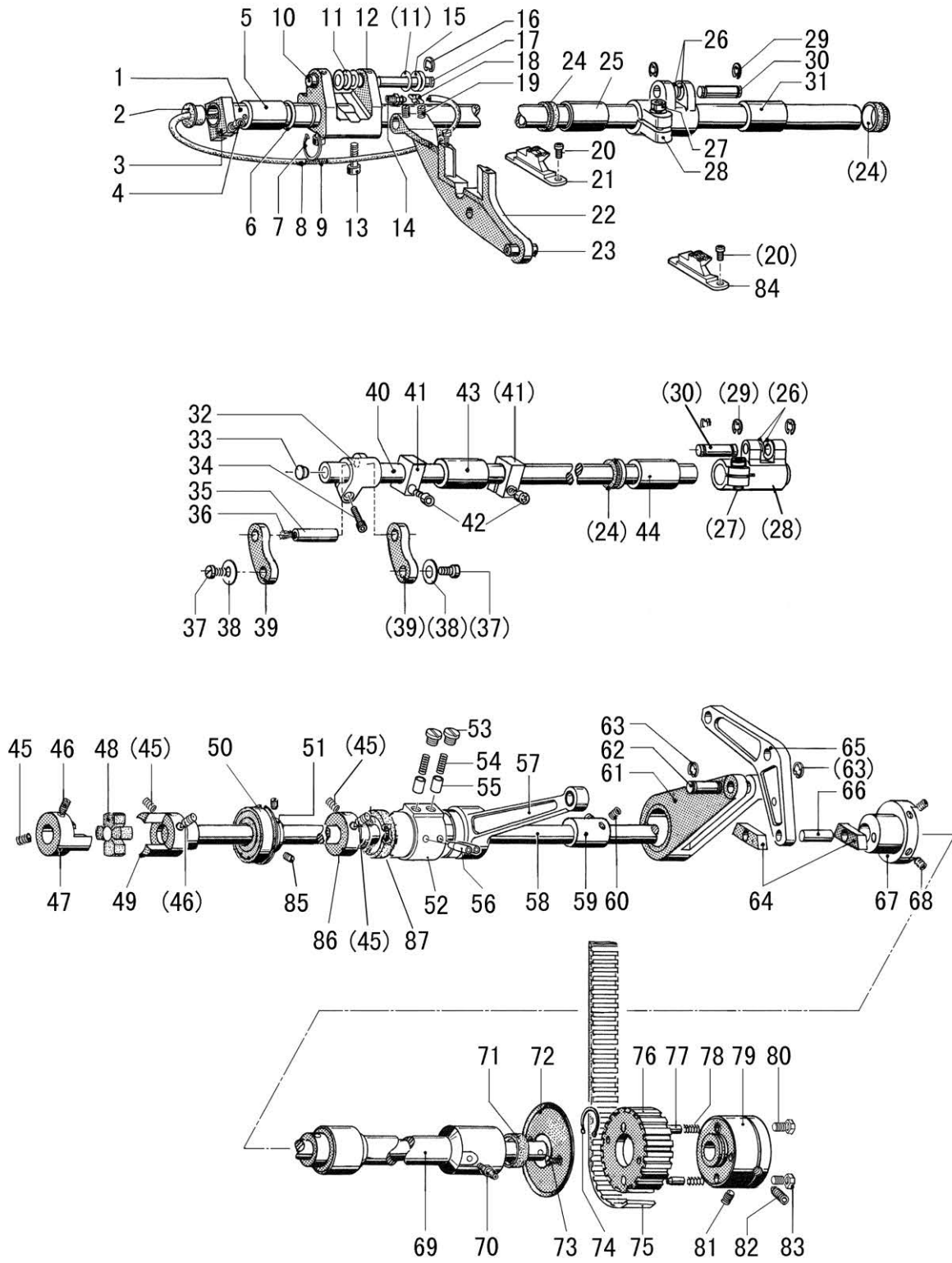

G.FEEDING AND FEED LIFTING & ROTATING HOOK SHAFT MECHANISM

Fig. No.	Part No.	Description	GC20688-1BDL	GC20688-2BDL	Remarks
G01	HE20I68001	Feed shaft	1	1	
G02	HF959G8001	Rubber cap	1	1	
G03	HF965G8001	Adjusting shaft collar	1	1	
G04	H415040120	Bolt	1	1	M4×12
G05	HF927E8001	Bushing(L)	1	1	
G06	HF931I8001	Thurst ring	1	1	
G07	HF930I8001	C-type retaining ring	1	1	
G08	HF941I8001	Tube	1	1	
G09	HF942I8001	Oil wick	1	1	
G10	HF937I8001	Bushing	4	4	
G11	HF945I8001	Washer	3	3	
G12	HF935I8001	Feed arm(L)	1	1	
G13	HF936I8001	Bolt(L)	2	2	
G14	HF956G8001	Oil joint	1	1	
G15	HF946I8001	Spring	2	2	
G16	H007013050	E-type retaining ring 5	1	1	
G17	HF944I8001	Pin	1	1	
G18	HF939I8001	Tube support	1	1	
G19	HF948I8001	Bolt	2	2	
G20	HF951I8001	Screw	2	2	
G21	HF950I8001	Feed dog	1		
G22	HF949I8001	Feed bracket	1	1	
G23	HF953I8001	Pin	1	1	
G24	HF929I8001	Oil seal	3	3	
G25	HF924E8002	Feed shaft bushing(L)	1	1	
G26	HF927I8001	Washer	4	4	
G27	H415060120	Bolt(R)	2	2	M6×12
G28	HF923I8001	Feed shaft arm(R)	2	2	
G29	H007013050	E-type retaining ring 5	4	4	
G30	HF926I8001	Pin	2	2	
G31	HF924E8001	Feed shaft bushing(R)	2	2	
G32	HF957I8001	Feed connecting arm(L)	1	1	
G33	HA719B0707	Rubber cap	1	1	
G34	H415050160	Bolt	1	1	M5×16
G35	HF958I8001	Pin(L)	1	1	
G36	HF961I8001	Oil wick	1	1	
G37	H401030080	Bolt	2	2	
G38	HF954I8001	Washer	2	2	
G39	HF952I8001	Feed link	2	2	
G40	HE20I78001	Shaft	1	1	
G41	HF965G8001	Adjusting shaft collar	2	2	
G42	H415040120	Bolt	2	2	M4×12
G43	HF927E8001	Bushing(L)	1	1	

G.FEEDING AND FEED LIFTING & ROTATING HOOK SHAFT MECHANISM

Fig. No.	Part No.	Description	GC20688-1BDL	GC20688-2BDL	Remarks
G44	HF924E8001	Bushing(R)	1	1	
G45	H428060100	Bolt	3	3	M6×10
G46	H429060100	Bolt	1	1	M6×10
G47	HF975J8001	Coupling claw(L)	1	1	
G48	HF978J8001	Toothed wreath	1	1	
G49	HF977J8001	Coupling craw(R)	1	1	
G50	H3205J0662	Ball bearing	2	2	
G51	HB42D61081	Bushing	1	1	
G52	HF987I8003	Bushing	1	1	
G53	HF992I8001	Bolt	1	1	
G54	H34412C110	Plunger spring	2	2	
G55	HF966I8001	Plunger	2	2	
G56	HA110E0672	Oil feeding pipe	2	2	
G57	HF971I7101	Feed rod	1	1	
G58	HE20I58001	Lower shaft	1	1	
G59	HF963I8001	Feed cam	1	1	
G60	H428060050	Bolt	2	2	M6×5
G61	HF919I7101	Lower feed connecting rod assy	1	1	
G62	HF926I8001	Pin	1	1	
G63	H007013050	E-type retaining ring 5	2	2	
G64	HF959H8001	Slide block	2	2	
G65	HF925I8001	Back cylinder connection	1	1	
G66	HF960H8001	Pin	1	1	
G67	HF917I8001	Lower feed cam	1	1	
G68	H428060080	Bolt	2	2	M6×8
G69	HF990I8001	Bushing(R)	1	1	
G70	HF956G8001	Oil joint	1	1	
G71	HF991I8001	Sealing ring	1	1	
G72	HF915I8001	Disk	1	1	
G73	HF916I8001	Stunk screw	2	2	
G74	H007009220	Retainer ring	1	1	
G75	HE20I88001	Toothed belt	1	1	
G76	HF908I8001	Belt pulley(D)	1	1	
G77	HF911I8001	Piston	2	2	
G78	H3404D0658	Presser spring	2	2	
G79	HF910I8001	Body	1	1	
G80	H431060120	Adjusting screw	2	2	M6×12
G81	H431080120	Bolt	1	1	M8×12
G82	H430080120	Bolt	1	1	M8×12
G83	H003002060	Nut	2	2	M6
G84	HG006I8001	Feed dog		1	
G85	H431040040	Screw	2	2	M4×4
G86	HE21I47101	Collar ASSY	1	1	
G87	HF988I8001	Oil seal	1	1	

H.HOOK SADDLE MECHANISM (RIGHT)

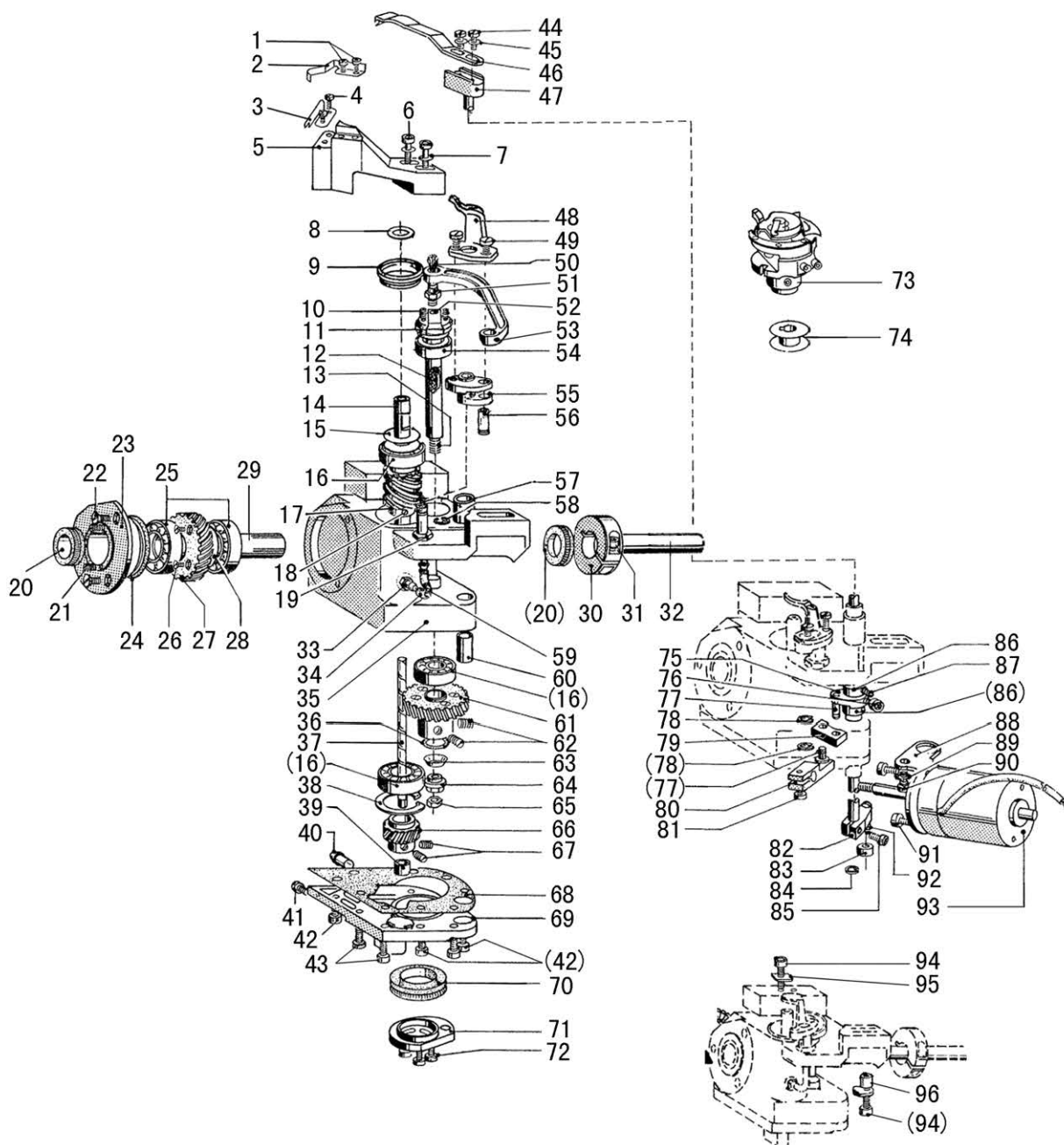

H.HOOK SADDLE MECHANISM (RIGHT)

Fig. No.	Part No.	Description	GC20688-1BDL	GC20688-2BDL	Remarks
H01	H402025060	Screw	2	2	M2. 5×6
H02	HF910J8001	Thread holding spring	1	1	
H03	HF908J8001	Fixed knife	1	1	
H04	H402025060	Screw	2	2	M2. 5×6
H05	HE40J68001	Fixed knife support bracket	1	1	
H06	H415050250	Bolt	2	2	M5×25
H07	H005005050	Washer	2	2	
H08	HF989J8001	Washer	5	5	
H09	HF991J8001	Oil drip ring	1	1	
H10	HF997J8001	Bolt	2	2	
H11	HF995J8001	Shaft	1	1	
H12	HF92AJ8001	Oil wick	1	1	
H13	H424050250	Bolt	1	1	M5×25
H14	HF981J8001	Hook shaft	1	1	
H15	HF992J8001	Washer	1	1	
H16	HF984J8001	Ball bearing	3	3	
H17	HF983J8001	Gear	1	1	
H18	H431050050	Bolt	2	2	M5×5
H19	HF946J8001	Pin(L)	1	1	
H20	HF964J8001	Oil seal	2	2	
H21	HF966J8001	Bolt	3	3	
H22	HF965J8001	Screw	3	3	
H23	HF962J8001	Lower shaft holder	1	1	
H24	HF960J8001	O ring	1	1	GB/T 3452.1 38.5×1.8
H25	HF963J8001	Ball bearing	2	2	
H26	H403030080	Screw	4	4	
H27	HF969J8001	Lower shaft gear	1	1	
H28	HF970J8001	Washer	1	1	
H29	HF967J8001	Driving shaft	1	1	
H30	HF973J8001	collar	1	1	
H31	H415060160	Bolt	1	1	M6×20
H32	HF971J8001	Shaft	1		
H33	HF956G8001	Oil feeding pipe(S)	1	1	
H34	HF949J8001	Tube	1	1	
H35	HF945J8001	Horizontal hook base	1	1	
H36	095018	Wave washer	1	1	
H37	HF990J8001	Lubrication shaft	1	1	
H38	H007007260	Retainer ring	1	1	
H39	HF956J8001	Bushing	1	1	
H40	HF947J8001	Oil feeding pipe(M)	2	2	
H41	H402030040	Bolt	1	1	M3×4
H42	H415040080	Bolt(short)	6	6	M4×8
H43	H415040120	Bolt(long)	3	3	M4×12

H.HOOK SADDLE MECHANISM (RIGHT)

Fig. No.	Part No.	Description	GC20688-1BDL	GC20688-2BDL	Remarks
H44	H415030060	Bolt	2	2	M3×6
H45	H005004030	Washer	2	2	
H46	HE40J88001	Driving knife	1	1	
H47	HF913J8001	Driving knife shaft	1	1	
H48	HE41J28001	Opener	1	1	
H49	HF90HJ8001	Screw	2	2	
H50	HF90AJ8001	Oil wick	1	1	
H51	HF999J8001	Adjusting pin	1	1	
H52	HF90BJ8001	Adjusting guide rail	1	1	
H53	HF90DJ8001	Opener shaft	1	1	
H54	HF996J8001	Bearing	1	1	
H55	HE41J18001	Opener setting bracket	1	1	
H56	HF90EJ8001	Pin	1	1	
H57	HF917J8001	Bushing	1	1	
H58	H007013040	E-type retaining ring	1	1	
H59	HF950J8001	Oil wick	1	1	
H60	HF919J8001	Bushing	1	1	
H61	HF91CJ7101	Gear base assy	1	1	
H62	H431050060	Bolt	2	2	M5×6
H63	H005014060	Belleville spring washer	1	1	
H64	HF91IJ8001	Nut	1	1	
H65	HF91JJ8001	Hexagonal nut	1	1	
H66	HF91AJ8001	Gear	1	1	
H67	H431050050	Bolt	2	2	M5×5
H68	HF954J8001	Sheet packing	1	1	
H69	HF953J8001	Cover	1	1	
H70	HF958J8001	Oil seal	1	1	
H71	HF942J8001	Thread trimmer cam	1	1	
H72	H415040080	Bolt	3	3	M4×8
H73	HE41J07101	Horizontal hook	1	1	
H74	HE41J38001	Bobbin	1	1	
H75	HF931J8001	Driving knife arm(S)	1	1	
H76	H415040120	Bolt	1	1	M4×12
H77	HF934J8001	Pin	2	2	
H78	H007013040	E-type retaining ring	2	2	
H79	HF933J8001	Driving knife connection	1	1	
H80	HF928J8001	Soloid setting bracket	1	1	
H81	H415040080	Bolt	1	1	M4×8
H82	HF937J8001	Driving knife arm(L)	1	1	
H83	HF940J8001	Roller	1	1	
H84	H007013030	E-type retaining ring	1	1	
H85	H415040120	Bolt	1	1	M4×12
H86	HF920J8001	collar	2	2	

H.HOOK SADDLE MECHANISM (RIGHT)

Fig. No.	Part No.	Description	GC20688-1BDL	GC20688-2BDL	Remarks
H87	H428050050	Bolt	2	2	M5×5
H88	HF922J8001	Soloid setting plate	1	1	
H89	H005018060	Washer	1	1	
H90	H415060120	Bolt	1	1	M6×12
H91	H415040100	Bolt	2	2	M4×10
H92	HF939J8001	Pin	1	1	
H93	HF926J7101	Thread trimmer solinoid	1	1	
H94	H415060220	Bolt	2	2	M6×22
H95	HF92BJ8001	Spacer	1	1	
H96	HF92CJ8001	Eccentric collar	1	1	

I.HOOK SADDLE MECHANISM (LEFT)

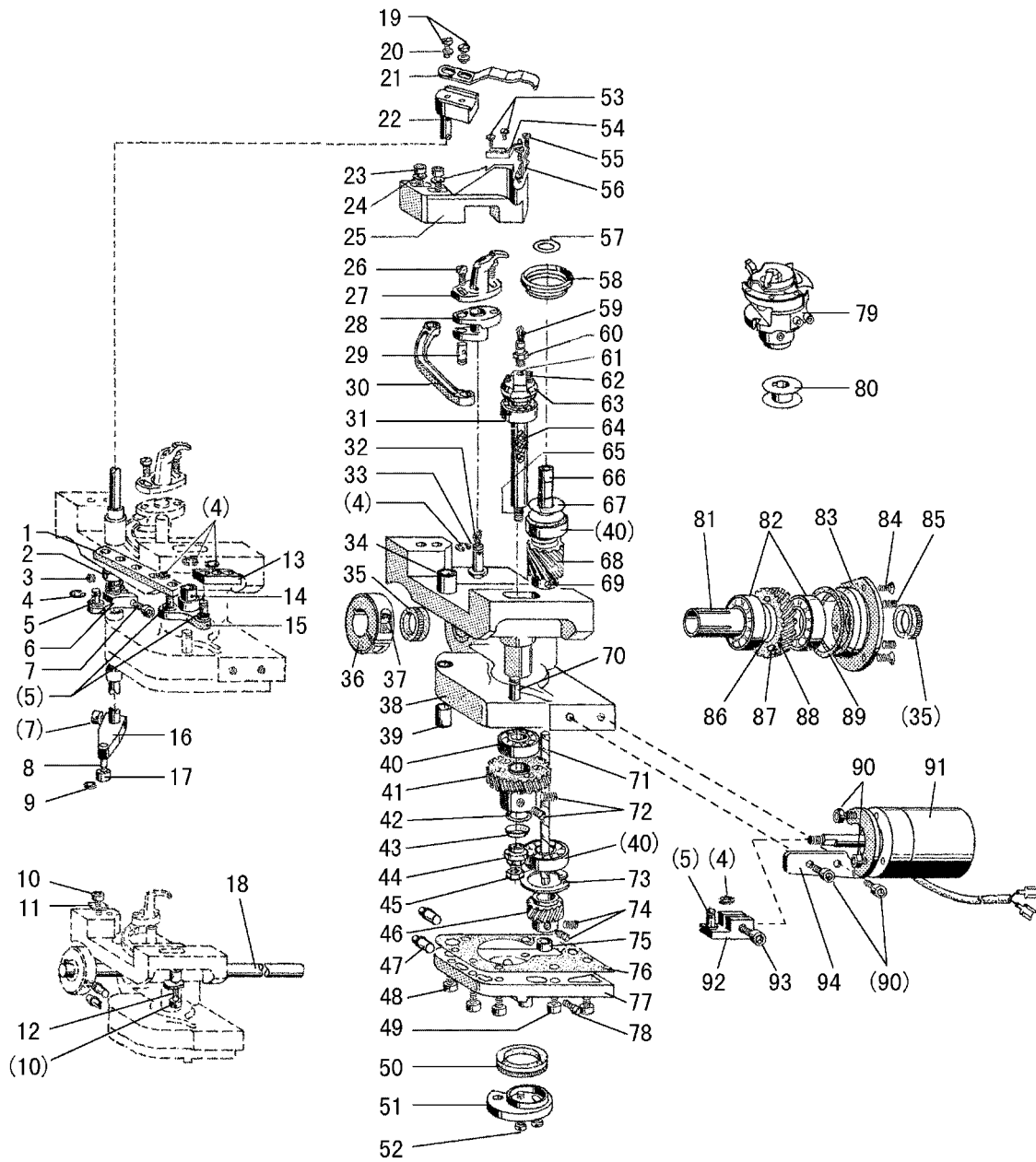

I.HOOK SADDLE MECHANISM (LEFT)

Fig. No.	Part No.	Description	GC20688-1BDL	GC20688-2BDL	Remarks
I01	HG013J8001	Link lever		1	
I02	HF920J8001	collar		1	
I03	H428050050	Bolt		1	M5×5
I04	H007013040	E-type stop ring 4		6	
I05	HF934J8001	Pin		4	
I06	HG012J8001	Thread trimmer arm(S)		1	
I07	H415040120	Bolt		2	M4×12
I08	HF939J8001	Pin		1	
I09	H007013030	E-type stop ring 4		1	
I10	H415060220	Bolt		2	M6×22
I11	HF92BJ8001	Spacer		1	
I12	HF92CJ8001	Eccentric collar		1	
I13	HG017J8001	Driving knife connection		1	
I14	HF919J8001	Bushing		1	
I15	HG016J8001	Crack		1	
I16	HF937J8001	Thread trimmer arm(L)		1	
I17	HF940J8001	Roller		1	
I18	HG021J8001	Driving shaft mandril		1	
I19	H415030060	Bolt		2	M3×6
I20	H005004030	Washer		2	
I21	HE40J88001	Driving knife		1	
I22	HF913J8001	Driving knife shaft		1	
I23	H415050250	Bolt		2	M5×25
I24	H005005050	Washer		2	
I25	HE40J68001	Fixed knife support bracket		1	
I26	HF90HJ8001	Screw		2	
I27	HE41J28001	Opener		1	
I28	HE41J18001	Opener setting bracket		1	
I29	HF90EJ8001	Pin		1	
I30	HF90DJ8001	Opener shaft		1	
I31	HF996J8001	Bearing		1	
I32	HG008J8001	Oil wick		1	
I33	HG007J8001	Oil joint		1	
I34	HF917J8001	Bushing		1	
I35	HF964J8001	Oil seal		2	
I36	HF973J8001	Collar		1	
I37	H415060200	Bolt		1	M6×20
I38	HG006J8001	Horizontal hook base		1	
I39	HF919J8001	Bushing		1	
I40	HF984J8001	Bearing		3	
I41	HF91CJ7101	Gear base assy		1	
I42	095018	Wave washer		1	
I43	H005014060	Belleville spring washer		1	

I.HOOK SADDLE MECHANISM (LEFT)

Fig. No.	Part No.	Description	GC20688-1BDL	GC20688-2BDL	Remarks
I44	HF91IJ8001	Adjusting block		1	
I45	HF91JJ8001	Hexagonal nut		1	
I46	HF91AJ8001	Driving gear		1	
I47	HF947J8001	Oil joint (M)		2	
I48	H415040080	Bolt (short)		6	M4×8
I49	H415040120	Bolt (long)		3	M4×12
I50	HF958J8001	Oil seal		1	
I51	HF942J8001	Thread trimmer cam		1	
I52	H415040080	Bolt		3	M4×8
I53	H402025060	Screw		2	M2.5×6
I54	HF910J8001	Thread holding spring		1	
I55	H402025060	Screw		2	M2.5×6
I56	HF908J8001	Fixed knife		1	
I57	HF989J8001	Uncork washer		5	
I58	HF991J8001	Hook support		1	
I59	HF90AJ8001	Oil wick		1	
I60	HF999J8001	Adjusting pin		1	
I61	HF90BJ8001	Adjusting guide rail		1	
I62	HF997J8001	Bolt		2	
I63	HF995J8001	Shaft		1	
I64	HF92AJ8001	Oil wick		1	
I65	H424050300	Bolt		1	M5×30
I66	HF992J8001	Spacer		1	
I67	HF981J8001	Hook shaft		1	
I68	HF983J8001	Driven gear		1	
I69	H431050050	Bolt		2	M5×5
I70	HG014J8001	Arm adjusting pin		1	
I71	HF990J8001	Lubrication shaft		1	
I72	H415050060	Bolt		2	M5×6
I73	H007007260	Retainer ring		1	
I74	H431050050	Bolt		2	M5×5
I75	HF956J8001	Bushing		1	
I76	HF954J8001	Sheet pack		1	
I77	HG010J8001	Cover (L)		1	
I78	H402030040	Bolt		1	M3×4
I79	HE41J07101	Horizontal hook assy		1	
I80	HE41J38001	Bobbin		1	
I81	HF967J8001	Driving shaft		1	
I82	HF963J8001	Boll bushing		2	
I83	HF962J8001	Lower shaft holder		1	
I84	HF965J8001	Screw		3	
I85	HF966J8001	Bolt		3	
I86	HF970J8001	Washer		1	

I.HOOK SADDLE MECHANISM (LEFT)

Fig. No.	Part No.	Description	GC20688-1BDL	GC20688-2BDL	Remarks
I87	HF969J8001	Driving gear		1	
I88	H403030080	Screw		4	
I89	HF960J8001	O-ring		1	GB/T 3452.1 38.5×1.8
I90	H415040100	Bolt		4	M4×10
I91	HF926J7101	Thread trimmer solenoid		1	
I92	HG019J8001	Solenoid setting bracket		1	
I93	H415040080	Bolt		1	M4×8
I94	HG020J8001	Solenoid setting plate		1	

J.OIL LUBRICATION MECHANISM

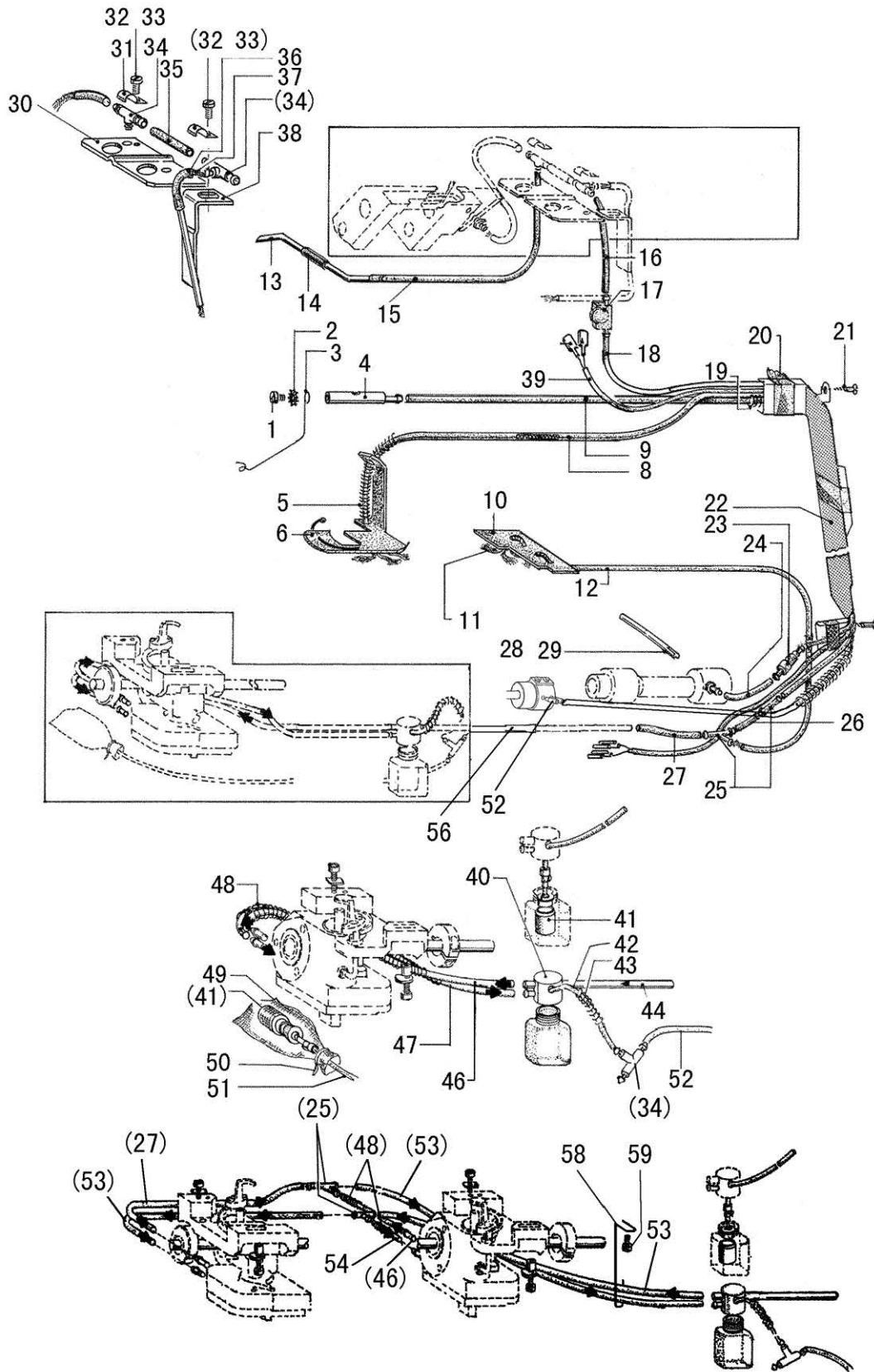

J.OIL LUBRICATION MECHANISM

Fig. No.	Part No.	Description	GC20688-1BDL	GC20688-2BDL	Remarks
J01	H401050080	Bolt	1	1	M5×8
J02	H005018050	Spacer	1	1	
J03	HF909K8001	Oil wick support	1	1	
J04	HF917K8001	Oil joint	1	1	
J05	HF908K8001	Tube guide	1	1	
J06	HF906K8001	Felt	1	1	
J08	HE20K58001	Oil tube	1	1	φ 3×φ 5×1150
J09	HE21K88001	Oil tube	1	1	φ 7×φ 5×950
J10	HF914K8001	Felt	1	1	
J11	HE21K58001	Oil wick	1	1	φ 4×1000
J12	HE21K38001	Oil tube	1	1	φ 7×φ 5×900
J13	HF948K8001	Pipe	1	1	
J14	HF950K8001	Oil tube	1	1	φ 3×φ 5×25
J15	HF949K8001	Hose	1	1	φ 3×φ 5×210
J16	HF936K8001	Oil pipe	1	1	φ 3×φ 5×60
J17	HF959K8001	Oil window	1	1	
J18	HE25K78001	Oil pipe	1	1	φ 3×φ 5×970
J19	HF919K8001	Spring	1	1	
J20	HF962K8001	Tape	1	1	
J21	HA04042160	Screw	2	2	
J22	HF960K8001	Guard plate	1	1	
J23	HF956K7101	Valve	1	1	
J24	HF955K8001	Main oil pipe	1	1	φ 3×φ 5×110
J25	HF920K8001	Oil joint	2	4	
J26	HF921K8001	Oil pipe	1	1	φ 7×φ 5×25
J27	HF922K8001	Oil pipe	1	1	φ 7×φ 5×120
J28	HF938K8001	Oil joint	1	1	
J29	HF939K8001	Oil pipe	1	1	φ 7×φ 5×140
J30	HF951K8001	Oil pipe setting plate	1	1	
J31	H3200K0170	Oil wick setting plate	2	1	
J32	H415040100	Screw	2	2	M4×10
J33	H005001040	Washer	2	2	
J34	H3210K0671	T-joint	3	3	
J35	HF942K8001	Hose	1	1	φ 3×φ 5×21
J36	HF947K8001	Hose	1	1	φ 3×φ 5×30
J37	HF946K8001	Oil wick	1	1	φ 3×φ 5×30
J38	HF943K8001	Oil pipe plate assy	1	1	
J39	HF92FJ7101	Wire assy	1	1	
J40	HF927K7101	Oil hose assy	1	1	
J41	HF963K7101	Filter pot assy	2	2	
J42	HE22K98001	Oil pipe	1	1	φ 3×φ 5×700
J43	HF930K8001	Support spring	1	2	

J.OIL LUBRICATION MECHANISM

Fig. No.	Part No.	Description	GC20688-1BDL	GC20688-2BDL	Remarks
J44	HF923K8001	Oil pipe	1	1	
J46	HE22K48001	Oil pipe	1	2	$\varnothing 7 \times \varnothing 5 \times 400$
J47	HE22K58001	Oil pipe	1	1	$\varnothing 7 \times \varnothing 5 \times 410$
J48	HF926K8001	Support spring	2	2	
J49	HF932K8001	Felt part	1	1	
J50	HA300I2040	Cable tie	1	1	
J51	HF934K8001	Oil pipe	1	1	$\varnothing 3 \times \varnothing 5 \times 250$
J52	HF937K8001	Oil pipe	1	1	$\varnothing 3 \times \varnothing 5 \times 600$
J53	HG006K8001	Oil pipe		3	$\varnothing 7 \times \varnothing 5 \times 100$
J54	HG005K8001	Oil pipe		1	$\varnothing 7 \times \varnothing 5 \times 60$
J55	HF922K8001	Oil pipe		1	$\varnothing 7 \times \varnothing 5 \times 120$
J56	HE23K08001	Oil pipe	1	1	
J58	HE25K98001	Tube support	1	1	
J59	H415050080	Screw	1	1	

K.ACCESSORIES

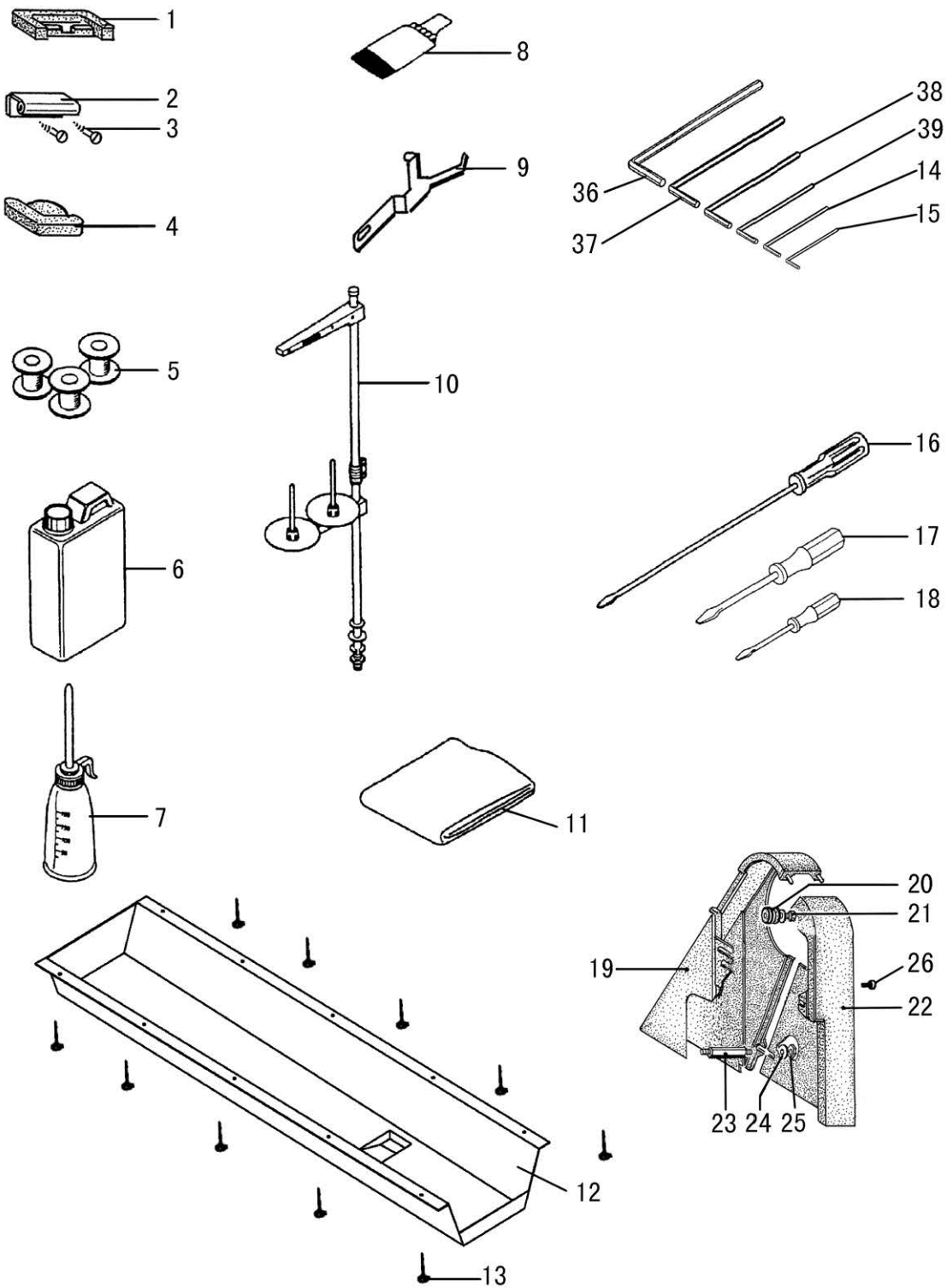

K.ACCESSORIES

Fig. No.	Part No.	Description	GC20688-1BDL	GC20688-2BDL	Remarks
K01	HA307J0671	Hinge support	2	2	
K02	HF914L8001	Hinge	2	2	
K03	H411060100	Screw	4	4	
K04	HF905L8001	Head cushion	2	2	
K05	HE41J38001	Bobbin	2	4	
K06	HA100J2170	Oil tank	1	1	
K07	H200400069	Oiler	1	1	
K08	JZDP1700G2301	Neddle	4		DP×17 #23
K08	JZDP1700G2302	Neddle		6	DP×17 #23
K09	HF913L8001	Detector setting plate	1	1	
K10	HA200J2030	Cotton stand assy	1		
K10	H3200L0120	Cotton stand assy		1	
K11	HA100J2180	Cover	1	1	
K12	HE20L48001	Oil plate	1	1	
K13	H801050200	Screw	10	10	
K14	HB00001025	Hexagonal wrench (2.5)	1	1	
K15	HB00001015	Hexagonal wrench (1.5)	1	1	
K16	HA300J2070	Screw driver(L)	1	1	
K17	HA300J2200	Screw driver(M)	1	1	
K18	HA300J2210	Screw driver(S)	1	1	
K19	HF908L8001	Belt guard(R)	1	1	
K20	HF915L8001	Rubber washer	1	1	
K21	H401060120	Bolt	1	1	
K22	HF907L8001	Belt guard(L)	1	1	
K23	HF911L8001	Bolt	1	1	
K24	H005001060	Washer	1	1	
K25	H7316E8001	Nut	1	1	
K36	HB00001060	Hexagonal wrench (6)	1	1	
K37	HB00001050	Hexagonal wrench (5)	1	1	
K38	HB00001040	Hexagonal wrench (4)	1	1	
K39	HB00001030	Hexagonal wrench (3)	1	1	

LPNEUMATIC CONTROL UNIT

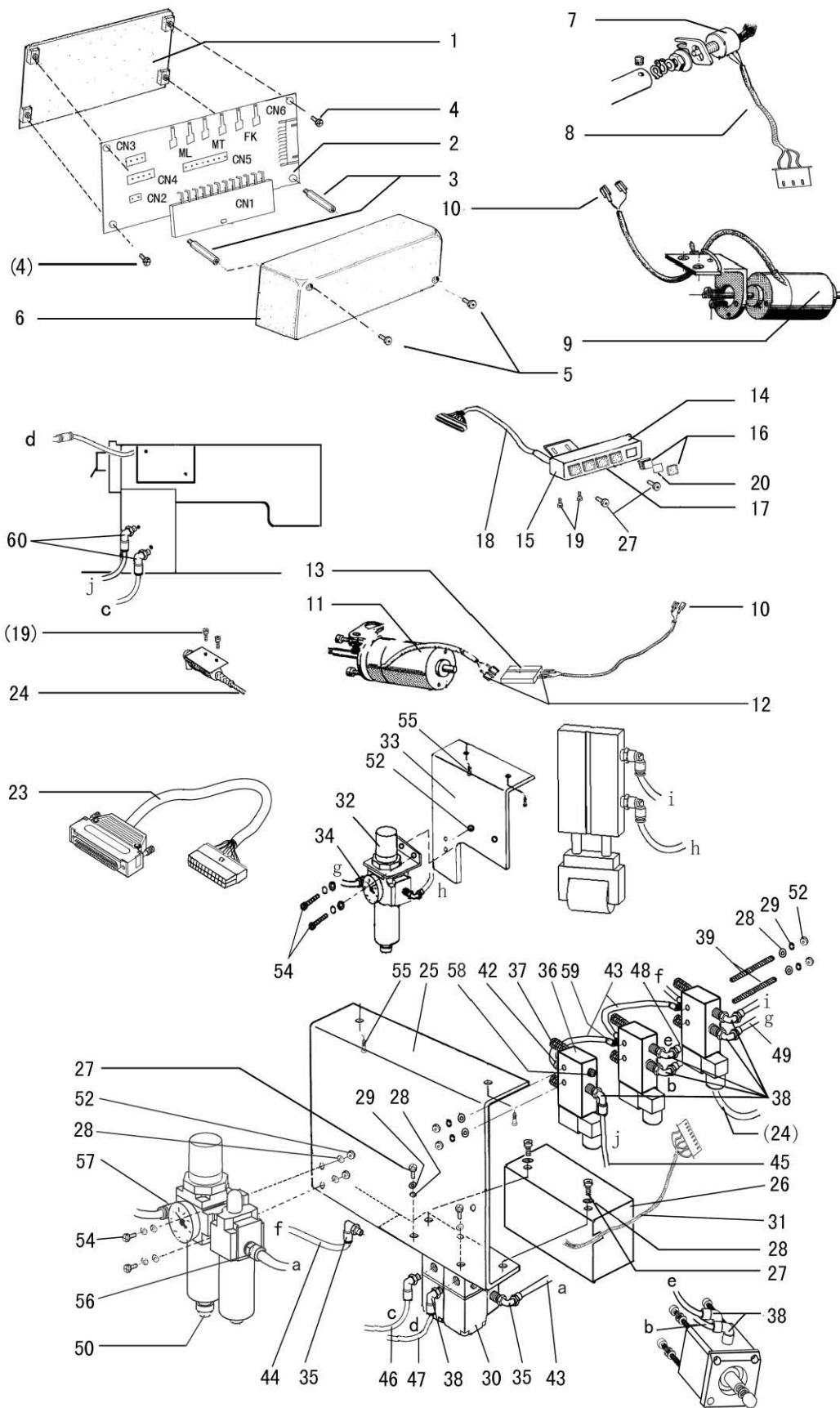

L.PNEUMATIC CONTROL UNIT

Fig. No.	Part No.	Description	GC20688-1BDL	GC20688-2BDL	Remarks
L01	HF930M8001	Connecting box base	1	1	
L02	HF924M8002	PCB board	1	1	
L03	HF932M8001	Connecting box screw	2	2	
L04	H409040160	Screw	2	2	
L05	H415030120	Screw	2	2	
L06	HF931M8001	Connecting box cover	1	1	
L07	HF922E8001	Rheostat	1	1	
L08	HE20E57101	Rheostat wire assy	1	1	
L09	HE20C57101	Tension release solenoid	1	1	
L10	HF921J8001	Wire joint	4	4	
L11	HF926J7101	Trimming solenoid	1	2	
L12	HF92HJ8001	Wire joint	4	6	
L13	HF92EJ8001	H type wire joint	1	1	
L14	HF934M8001	Button set frame	1	1	
L15	HF933M8001	Button set board	1	1	
L16	HF937M8001	Button with light	3	3	
L17	HF937M8002	Button without light	2	2	
L18	HE20M57101	Button wire assy	1	1	
L19	H415040060	Screw	4	4	
L20	HF940M8001	Plotting	5	5	
L22	HF929M7101	Count to alarm wire assy	1	1	
L23	HF925M7102	Control box wire assy	1	1	
L24	HE20M97101	Reset button assy	1	1	
L25	HF917M8001	Solenoid valve set board	1	1	
L26	HF941M8001	Solenoid valve cover	1	1	
L27	H409040100	Screw	4	4	
L28	H005001040	Washer	8	8	
L29	H005008040	Spring washer	4	4	
L30	HF906M7101	Solenoid valve assy	1	1	
L31	HF927M7101	Solenoid valve wire assy	1	1	
L32	H4915N8001	Filter with regulator	1	1	
L33	H4923N8001	Bracket	1	1	
L34	HF912M8001	Wire joint	2	2	
L35	H4921N8001	Wire joint	2	2	
L36	H4918N8001	Solenoid valve	3	3	
L37	H4924N8001	Exhaust muffler	6	6	
L38	HF959M8001	Wire joint	9	9	
L39	HG00B88001	Screw	2	2	
L40	H005008040	Spring washer	2	2	
L41	H005001040	Washer	2	2	
L42	H4917N8001	Wire joint	1	1	
L43	HF958M8001	Windpipe	3	3	
L44	HF915M8001	Windpipe	1	1	

L.PNEUMATIC CONTROL UNIT

Fig. No.	Part No.	Description	GC20688-1BDL	GC20688-2BDL	Remarks
L45	HF914M8002	Windpipe	1	1	
L46	HF914M8003	Windpipe	1	1	
L47	HF914M8001	Windpipe	1	1	
L48	HF914M8004	Windpipe	2	2	
L49	HE21M48001	Windpipe	2	2	
L50	HF905M8001	Air source units	1	1	
L52	H003002040	Nut	8	8	
L53	H005001040	Washer	1	1	
L54	HZ11040120	Screw	2	2	
L55	H801050200	Screw	4	4	
L56	H4919N8001	Wire joint	1	1	
L57	H4914N8001	Wire joint	1	1	
L58	HF960M8001	Screw plug	1	1	
L59	HG119M8001	Wire joint (Y)	2	2	
L60	HF937E8001	Wire joint	1	1	

GAUGE PARTS LIST

Needle gauge	3. 2mm	6. 4mm	8mm	8mm	10mm	12mm	Pcs.	16mm	Pcs.
Needle bar connecting stud	HG017G8001	HG019G8001	HG006G8001		HG010G8001	HG013G8001	1	HG015G8001	1
Outer presser foot	HG021F8001	HG025F8001	HG005F8001		HG013F8001	HG016F8001	1	HG018F8001	1
Finger gusrd	HG022F8001	HG006F8001			HG014F8001		1	HG019F8001	1
Inner presser foot	HG023F8001	HG026F8001	HG008F8001		HG009F8001	HG010F8001	1	HG011F8001	1
Feed dog	HG010I8001	HG011I8001	HG006I8001	HG006I8002	HG007I8001	HG008I8001	1	HG009I8001	1
Needle plate	HG014B8001	HG015B8001	HG007B8001		HG008B8001	HG009B8001	1	HG010B8001	1
Slide Plate left	HF980B8001		HG005B8001			HG013B8001	1	HG011B8001	1
Slide Plate right	HF981B8001		HG006B8001				1	HG012B8001	1
Thread guide	HG007G8001				HG011G8001		1	HF971G8001	2
Screw	HG008G8001						1	HF972G8001	2

SHANGHAI HUIGONG NO.3 SEWING MACHINE FACTORY

ADD: 1418, Yishan Road, Shanghai, China

Zip Code: 201103

Overseas Business: TEL: 86-21-64853303 FAX: 86-21-64854304

E-mail: highlead@online.sh.cn <http://www.highlead.com.cn>

The description covered in this manual is subject to change for improvement of the commodity without notice

2008.5. Printed

From the library of: Superior Sewing Machine & Supply LLC